

DENSO

Diesel Injection Pump

SERVICE MANUAL

**TOYOTA LAND CRUISER (200 SERIES)
1VD-FTV ENGINE
COMMON RAIL SYSTEM (CRS)
OPERATION**

September, 2007

DENSO CORPORATION

00400609E

© 2007 DENSO CORPORATION

All Rights Reserved. This book may not be reproduced or copied, in whole or in part, without the written permission of the publisher.

Operation Section

1. APPLICABLE VEHICLE AND PRODUCT INFORMATION

1.1	Introduction	1-1
1.2	Applicable Vehicle	1-1
1.3	Layout of Main Components	1-2
1.4	Applicable Product List	1-3
1.5	CRS Construction	1-4

2. SUPPLY PUMP

2.1	Outline	1-5
2.2	Suction Control Valve (SCV)	1-6

3. RAIL

3.1	Outline	1-7
-----	---------	-----

4. INJECTOR

4.1	Outline	1-8
-----	---------	-----

5. CONTROL SYSTEM

5.1	Control System Diagram	1-9
5.2	Engine Electronic Control Unit (ECU)	1-10
5.3	EDU	1-10
5.4	Sensors	1-11
5.5	Exhaust Gas Recirculation (EGR) Valve	1-13

6. FUEL INJECTION CONTROL

6.1	Outline	1-14
6.2	Injection Pattern	1-14

7. ENGINE ECU DIAGNOSTIC TROUBLE CODES (DTC)

7.1	DTC Table	1-15
-----	-----------	------

8. ATTACHED MATERIALS

8.1	Engine ECU External Wiring Diagram	1-18
8.2	Connector Terminal Layout	1-20

1. APPLICABLE VEHICLE AND PRODUCT INFORMATION

1.1 Introduction

- As a result of a model change, TOYOTA's first V-8 engine, the "1VD-FTV" has been installed in the TOYOTA LAND CRUISER (200 series). This manual describes the Common Rail System (CRS) installed on the LAND CRUISER (200 series) 1VD-FTV engine.

For common information to all CRSs, refer to the previously published CRS general addition manual (Doc ID: 00400076E).

[Items common to all CRSs: CRS development process, system control, construction and operation of main components (supply pump, rail, injectors), sensors and actuators.]

1.2 Applicable Vehicle

Vehicle Name	Vehicle Model	Engine Model	Engine Displacement	Destination	Release Date
LAND CRUISER (200 Series)	VDJ200	1VD-FTV	4.5L	Europe, Australia, Russia, Middle East, General	August. 2007

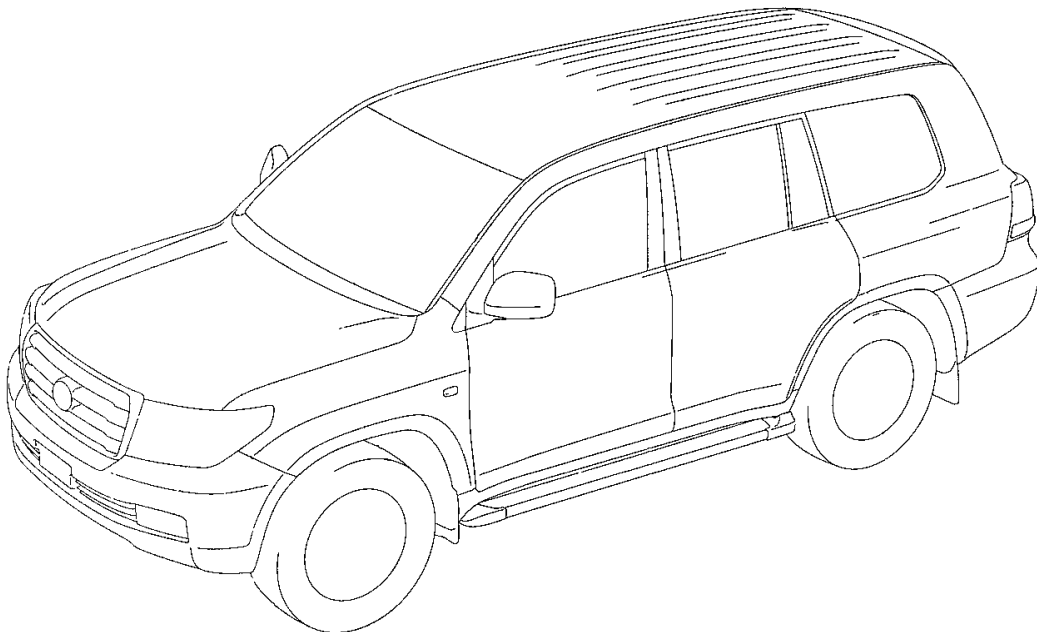

Q002500E

1.3 Layout of Main Components

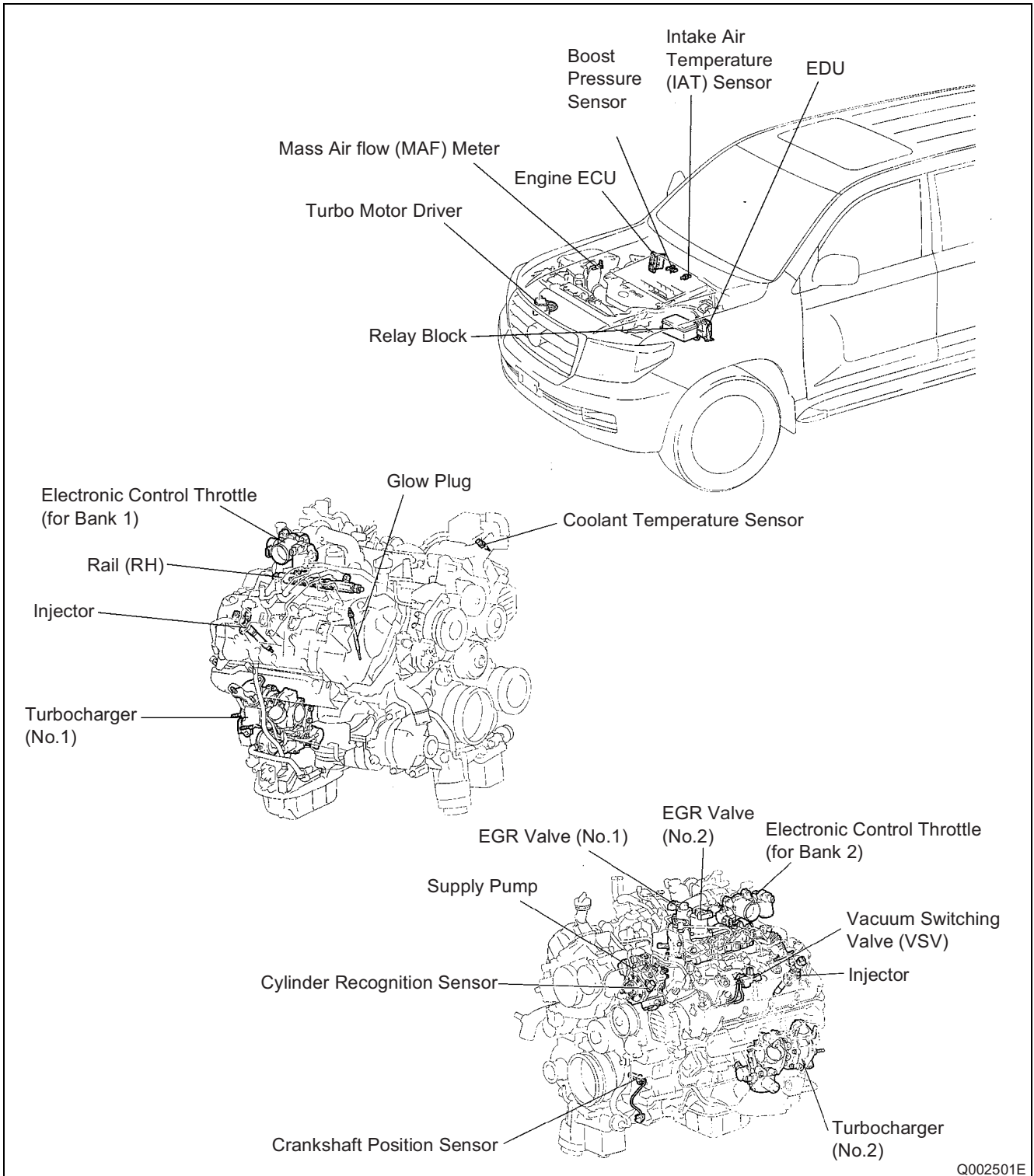

1.4 Applicable Product List

Parts Name	DENSO Part Number	Manufacturer Part Number	Remarks
Supply Pump	294050-023#	22100-51030	HP4
	294050-024#	22100-51040	
Injector	095000-673#	23670-51020	8 injectors
Rail	HU095440-100#	23810-0W010	RH
	HU095440-104#	23820-0W010	LH
Engine ECU	275900-002#	89661-60F60	AT, Europe
	275900-003#	89661-60F70	AT, Australia, Russia
	275900-004#	89661-60F80	AT, General, Middle East
	275900-005#	89661-60F90	AT, General
	275900-006#	89661-60G00	AT, EGR, General
	275900-007#	89661-60G10	AT, General, Middle East
	275900-008#	89661-60G20	MT, General
	275900-009#	89661-60G30	MT, EGR, General
EDU	101310-578#	89870-60070	2 EDUs
Crankshaft Position Sensor	029600-074#	90919-05029	
Cylinder Recognition Sensor	029600-149#	90919-05072	
Coolant Temperature Sensor	071560-005#	89422-16010	
Accelerator Pedal Module	198800-359#	78120-60410	
EGR Valve No.1	135000-727#	23620-51010	RH
EGR Valve No.2	135000-728#	25630-51010	LH

1.5 CRS Construction

- The illustration below is an outline of the CRS. The primary feature of this system is the use of two rails and two EDUs in order to comply with the V-8 engine. When looking into the engine compartment from the driver's seat, the two rails are positioned above the right and left banks (hereafter: right bank rail = "rail RH", left bank rail = "rail LH"). EDU No.1 and No.2 each control four injectors.

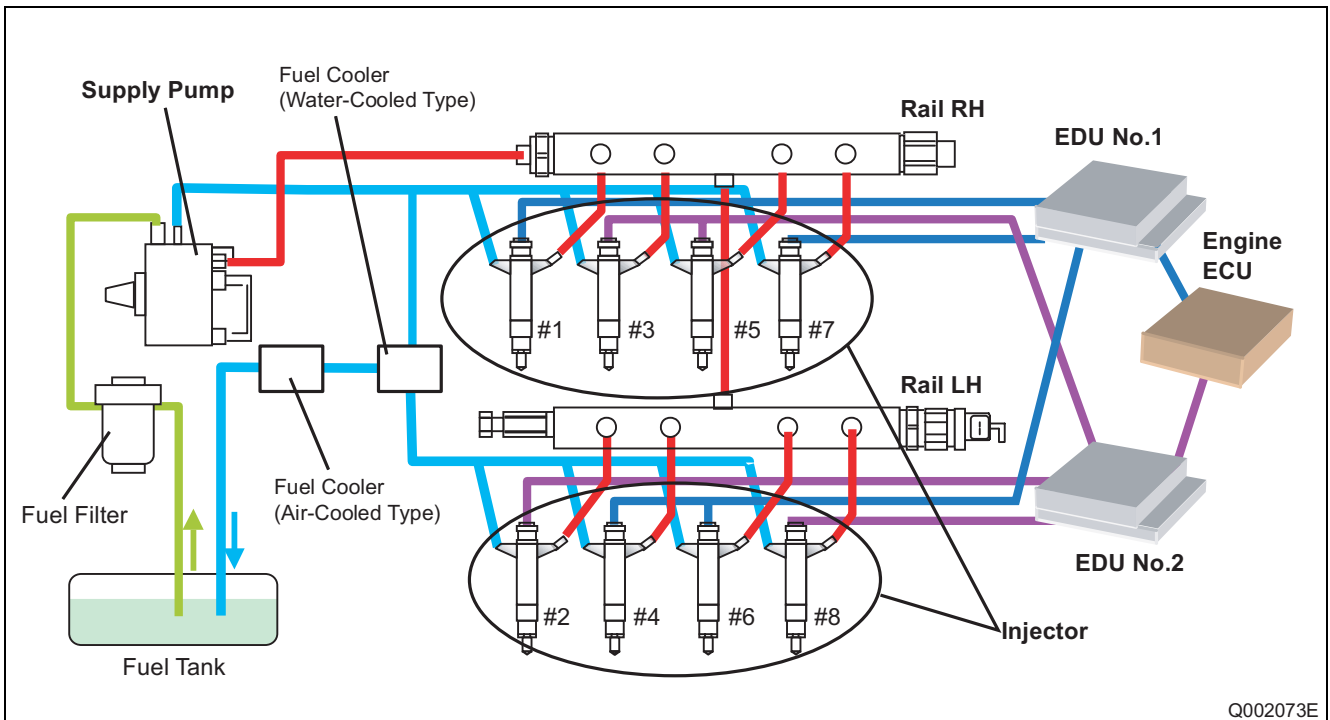

2. SUPPLY PUMP

2.1 Outline

- The CRS used in the TOYOTA LANDCRUISER (200 Series) is equipped with an HP4 supply pump.

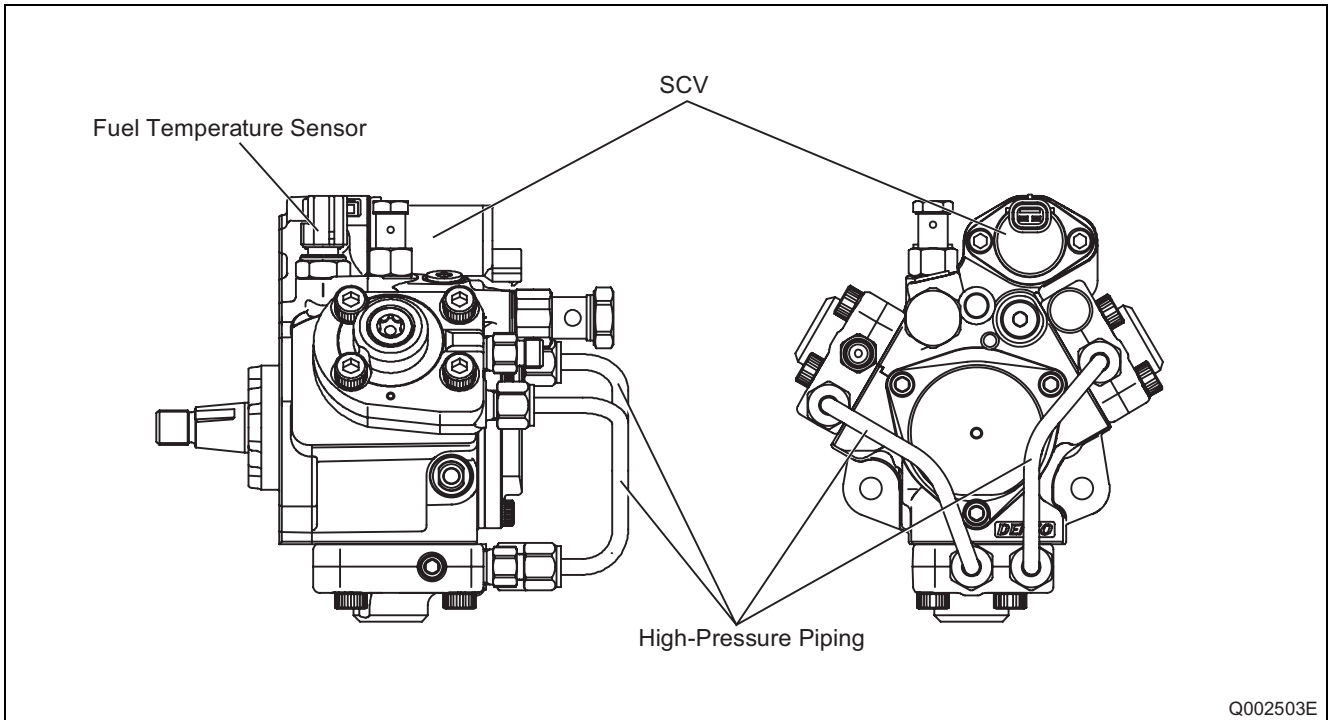

Supply Pump Specifications

Item		Content
Plunger Diameter		Ø8.5 × 3
Cam Lift		8.8 mm
Rotation		Clockwise viewed from drive side
SCV	Terminal Resistance (Rated Voltage)	2.10 ± 0.15 Ω (20 °C) 12 V
	Control Type	Normally closed

2.2 Suction Control Valve (SCV)

- A conventional normally closed type SCV has been adopted for use with the 1VD-FTV engine.

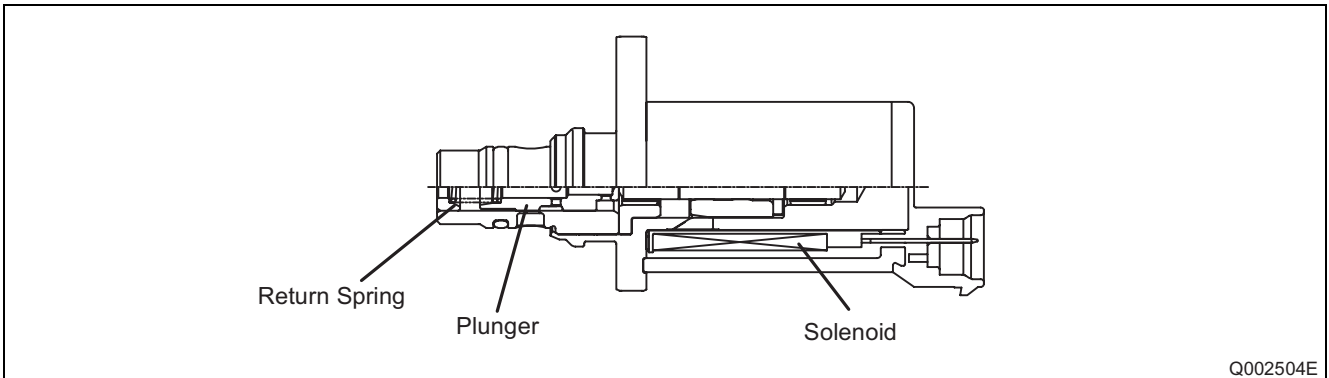

Operation Concept Diagram

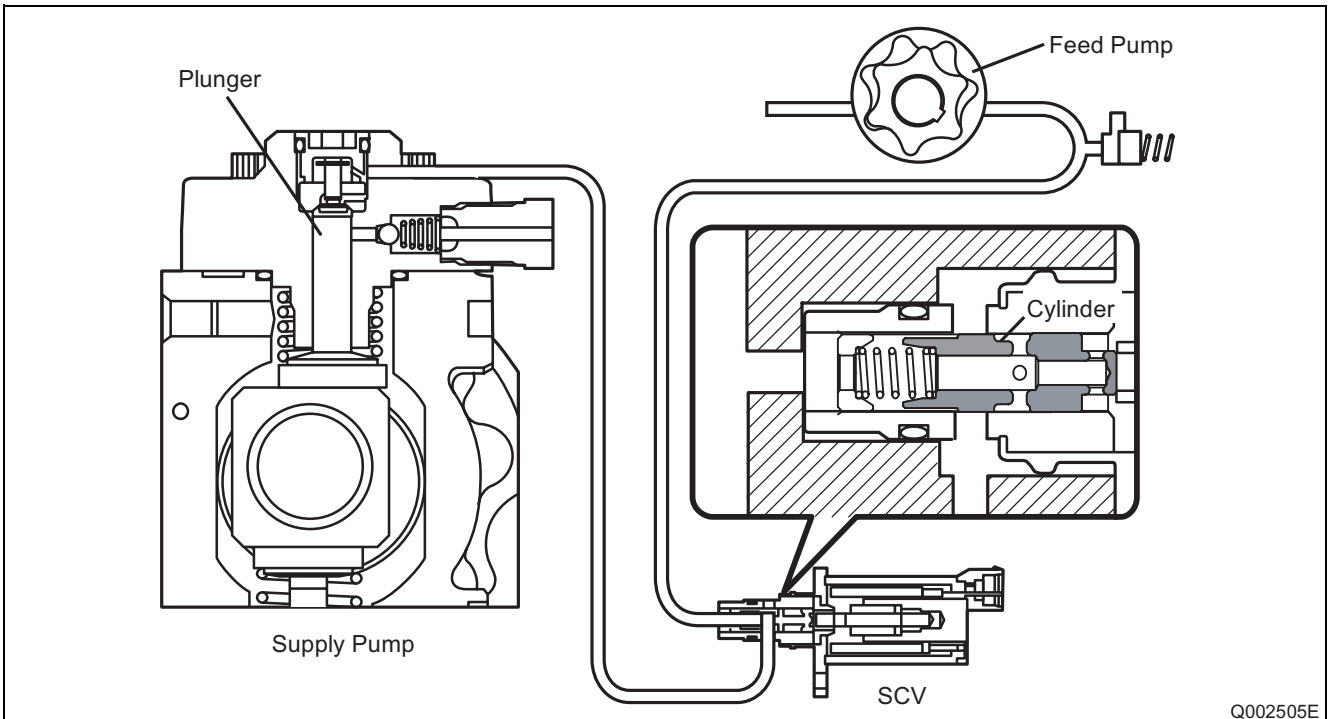

Operation

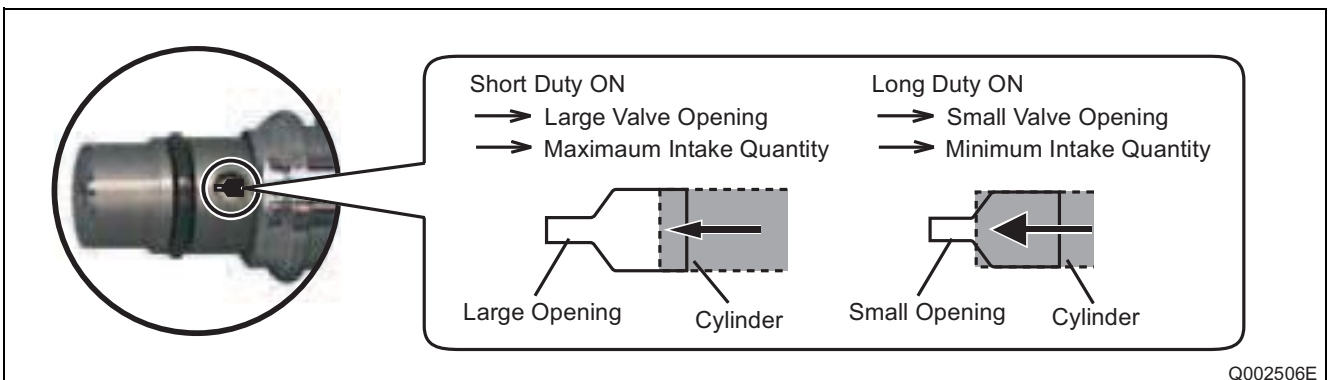

3. RAIL

3.1 Outline

- Rail RH is provided with a fuel inlet for connection with rail LH. Rail internal fuel pressure is controlled by a rail pressure sensor (Pc sensor) attached to rail RH, and the engine ECU. In addition, when rail internal pressure becomes abnormally high, a pressure limiter attached to rail LH opens to release excess pressure.

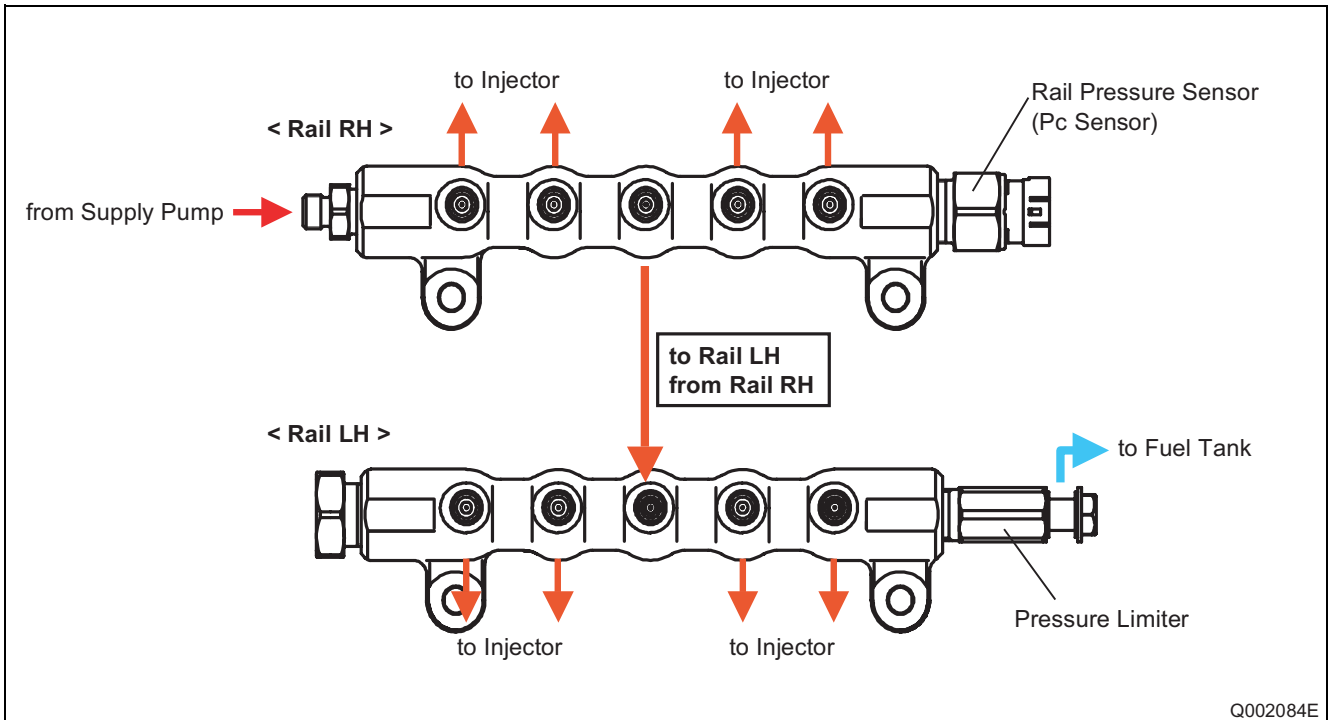

4. INJECTOR

4.1 Outline

- As shown in the figure below, the CRS used in the TOYOTA LANDCRUISER 70 is equipped with eight solenoid injectors with QR codes.

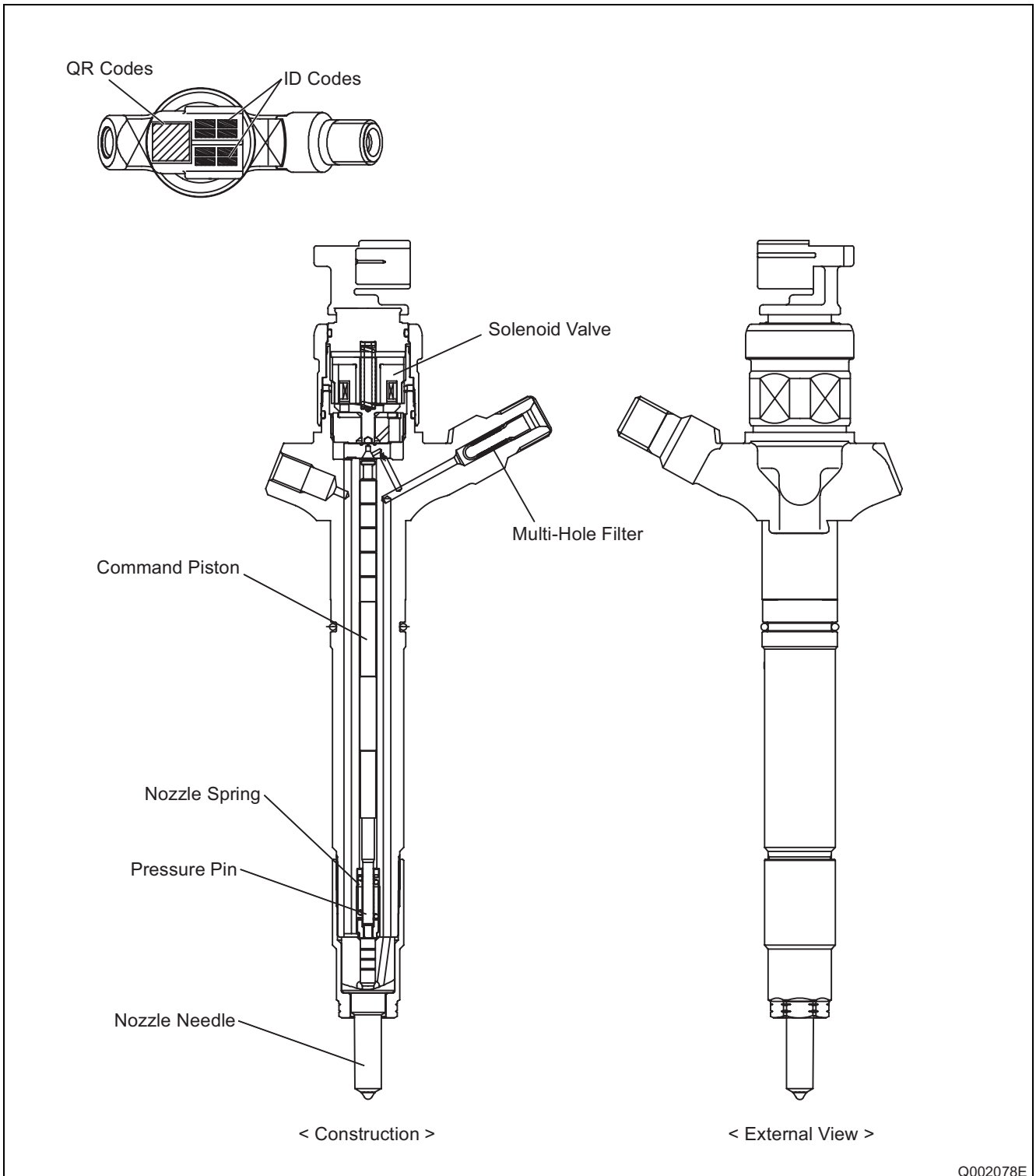

5. CONTROL SYSTEM

5.1 Control System Diagram

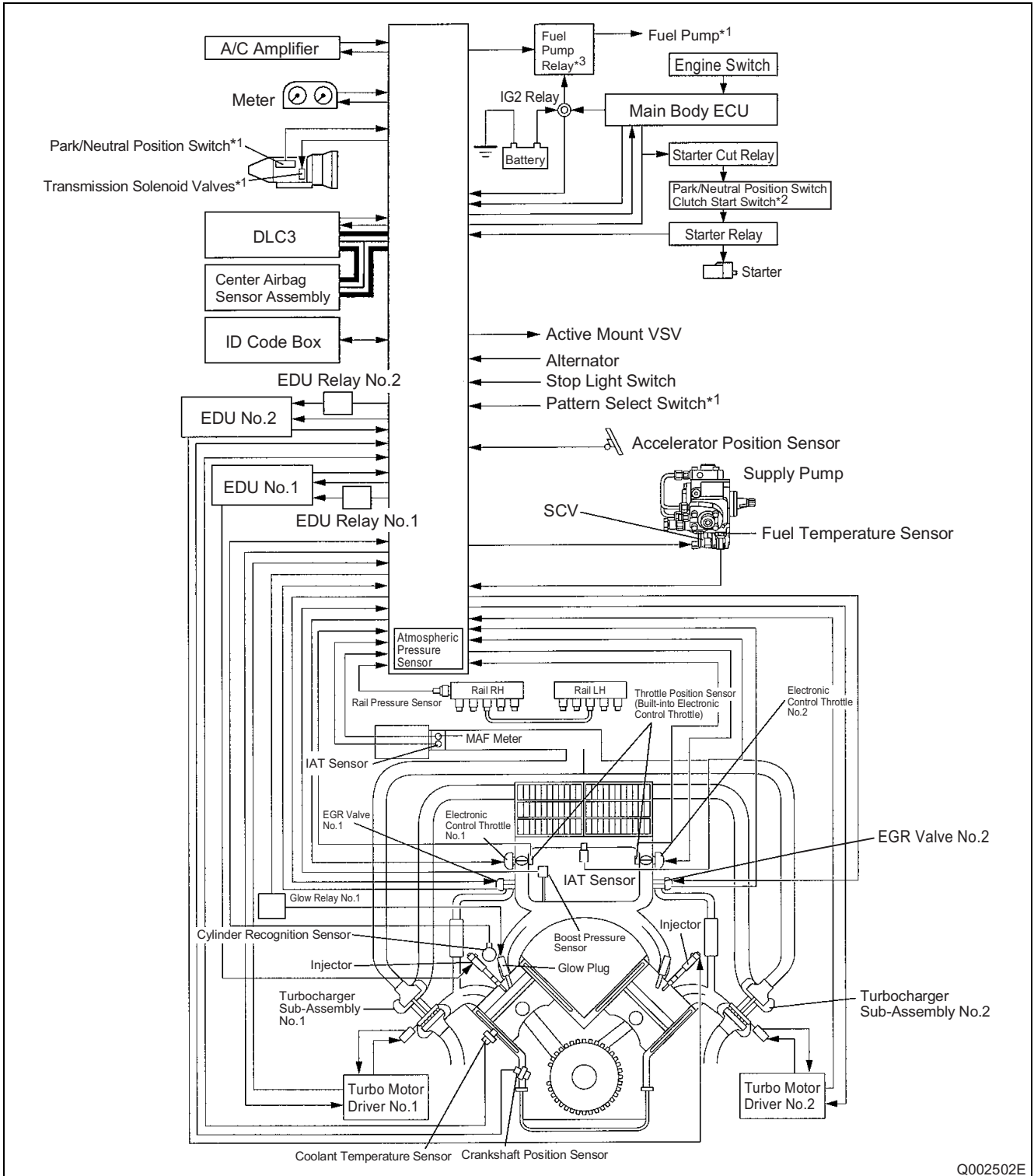

Q002502E

< NOTE >

- *1 : Only for AT models
- *2 : Only for MT models
- *3 : Only for dual fuel tank models

5.2 Engine Electronic Control Unit (ECU)

- The figure below is an external view of the engine ECU. For details on the connector terminal layout, refer to "8.2 Connector Terminal Layout".

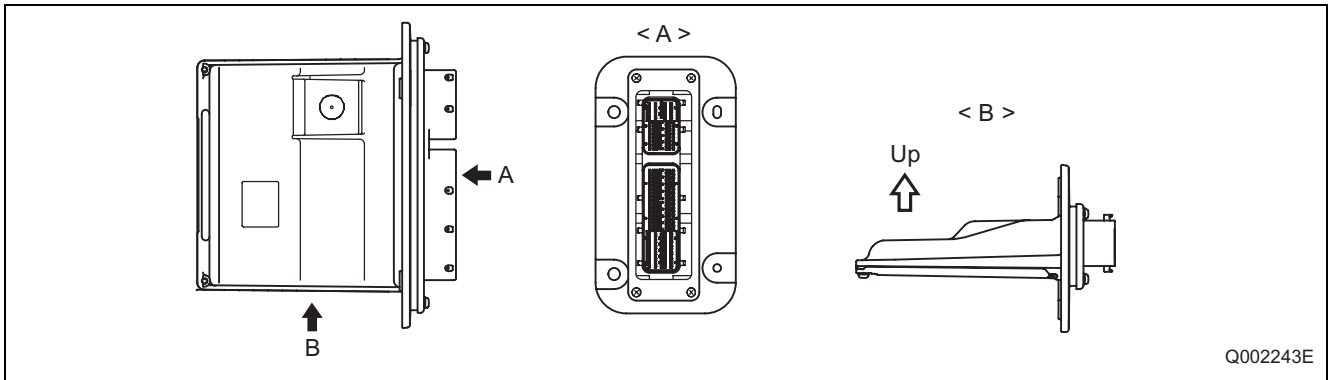

Q002243E

5.3 EDU

- The CRS for the TOYOTA LAND CRUISER (200 series) uses two EDUs (No.1 and No.2). Control of the eight injectors is divided into two systems. EDU No.1 controls cylinders 1, 4, 6, and 7, while EDU No.2 controls cylinders 2, 3, 5, and 8. The following page displays a circuit diagram for one system.

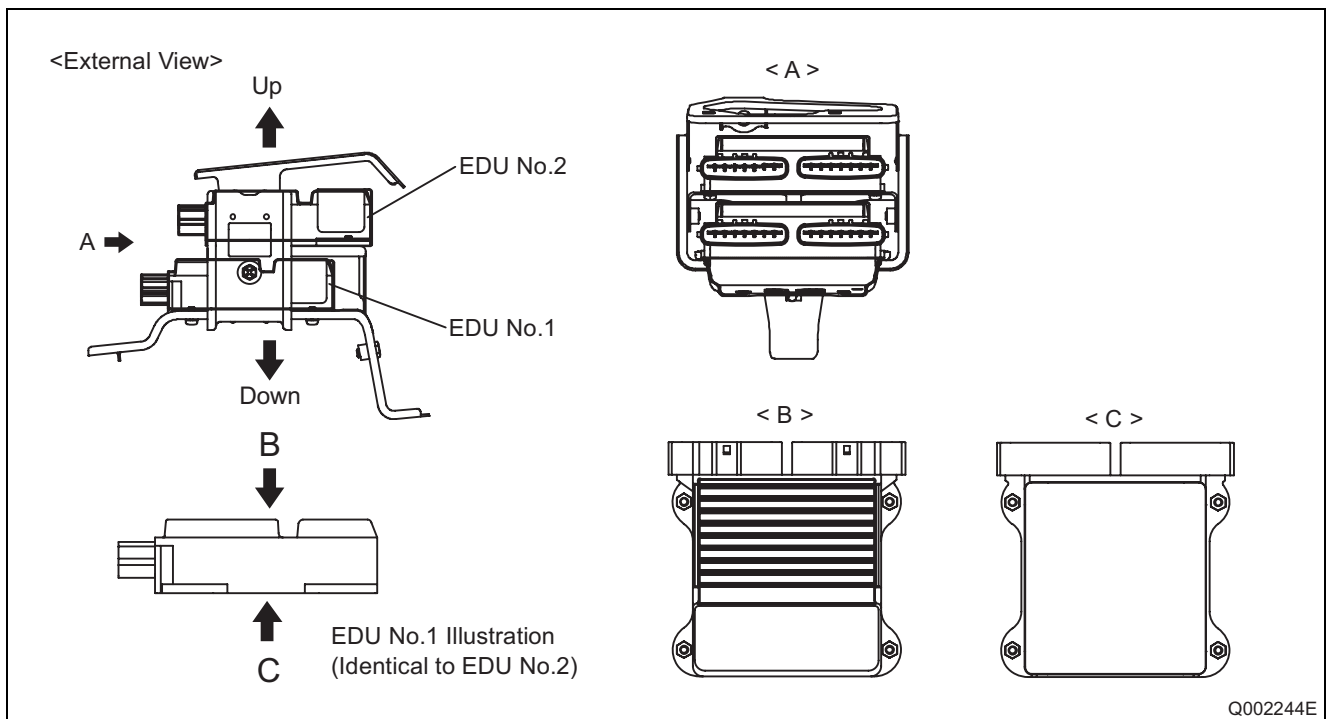

EDU No.1 Illustration
(Identical to EDU No.2)

Q002244E

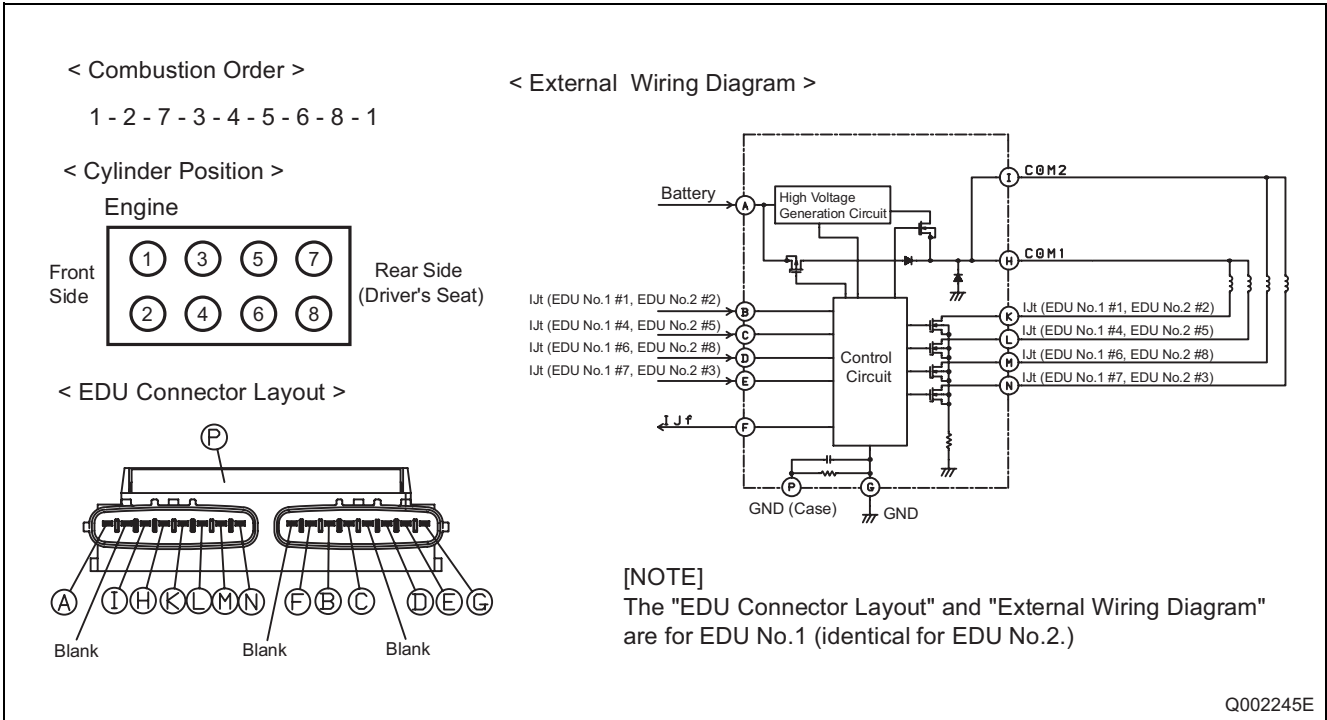

5.4 Sensors

(1) Crankshaft Position Sensor

- The crankshaft position sensor is a Magnetic Pick Up (MPU) type sensor. The crankshaft position sensor is attached to the crankshaft timing gear, and detects NE pulses according to the number of timing gear teeth. There are 34 timing gear teeth plus two missing teeth. When the two missing teeth pass the crankshaft position sensor, Top Dead Center (TDC) is accurately detected due to the pulse change.

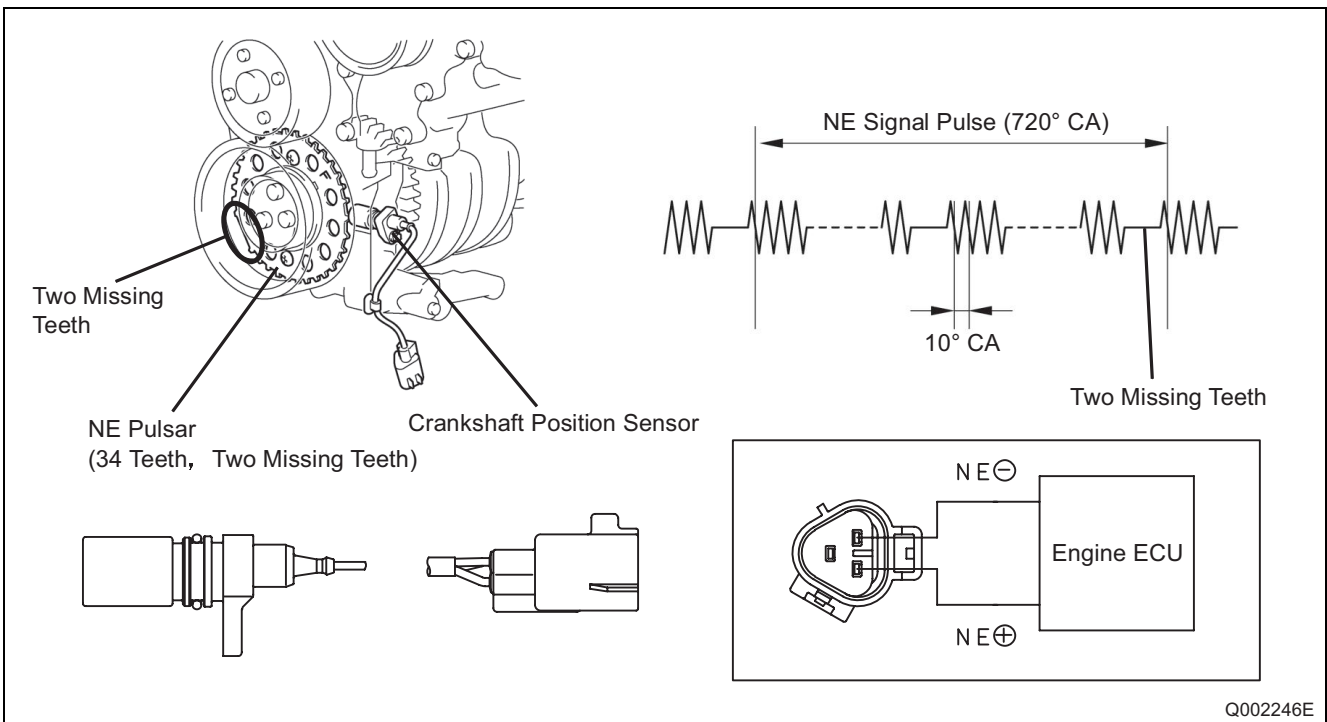

(2) Cylinder Recognition Sensor

- The cylinder recognition sensor is a Magnetic Pick Up (MPU) type sensor. The cylinder recognition sensor is attached to the camshaft timing gear. When the protrusion on the timing gear (G pulsar) passes the sensor, cylinder recognition is performed according to the pulse change.

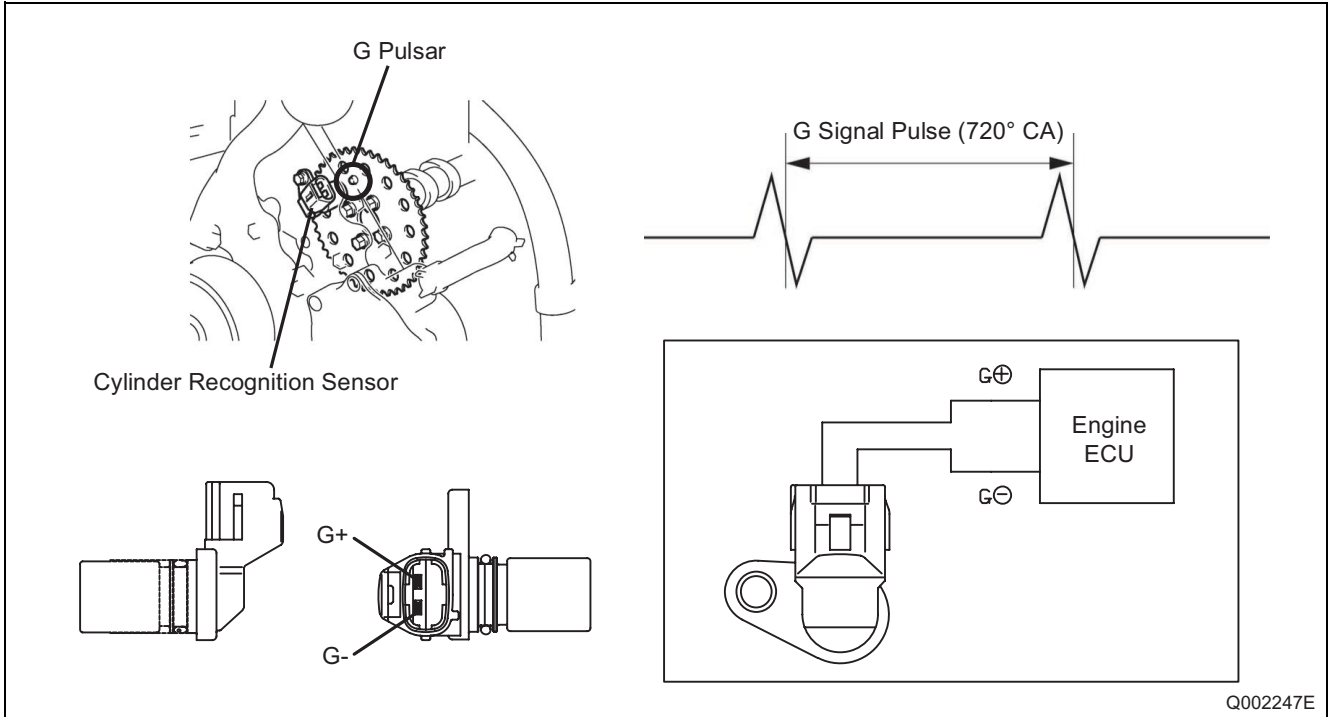

(3) Accelerator Position Sensor (Accelerator Pedal Module)

- The accelerator position sensor is a Hall element type sensor. Accelerator position is converted to an electrical signal that is output to the engine ECU.

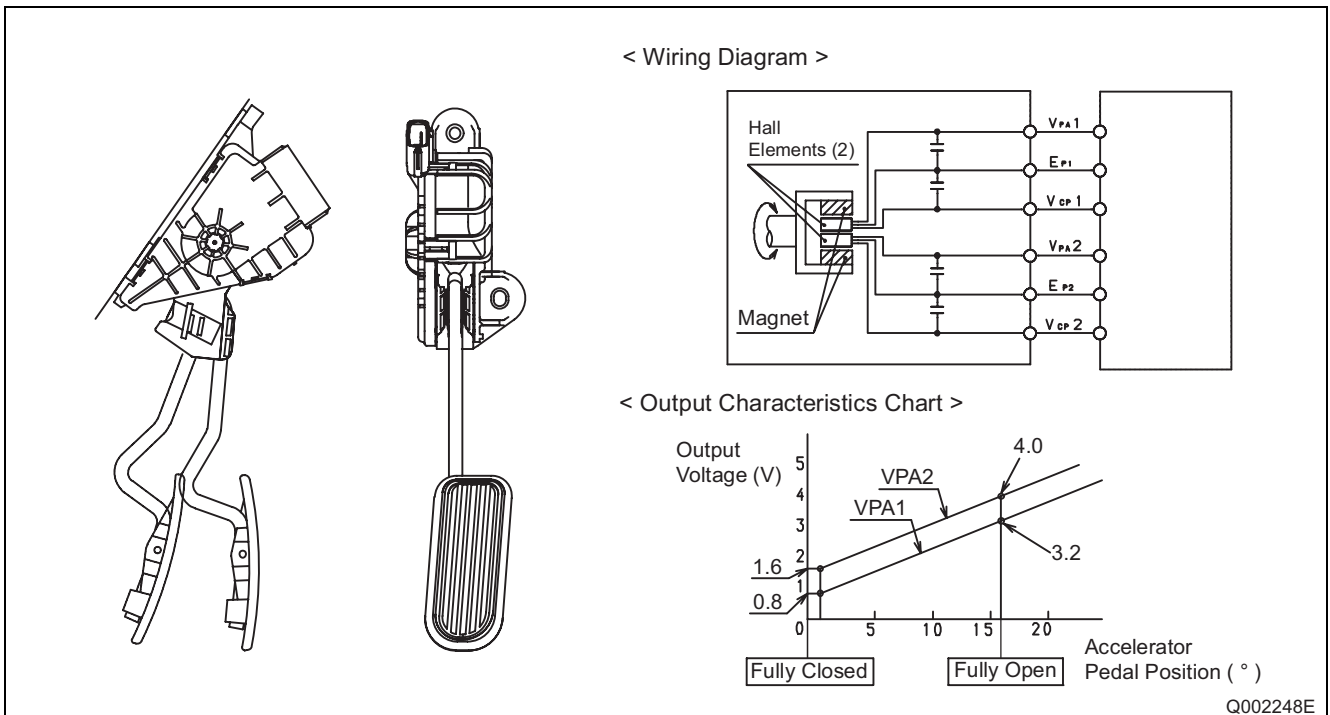

(4) Coolant Temperature Sensor

- The coolant temperature sensor detects the temperature of the engine coolant. The coolant sensor contains a built-in thermistor that undergoes changes in resistance according to coolant temperature. The change in coolant temperature is detected using the change in the thermistor resistance value.

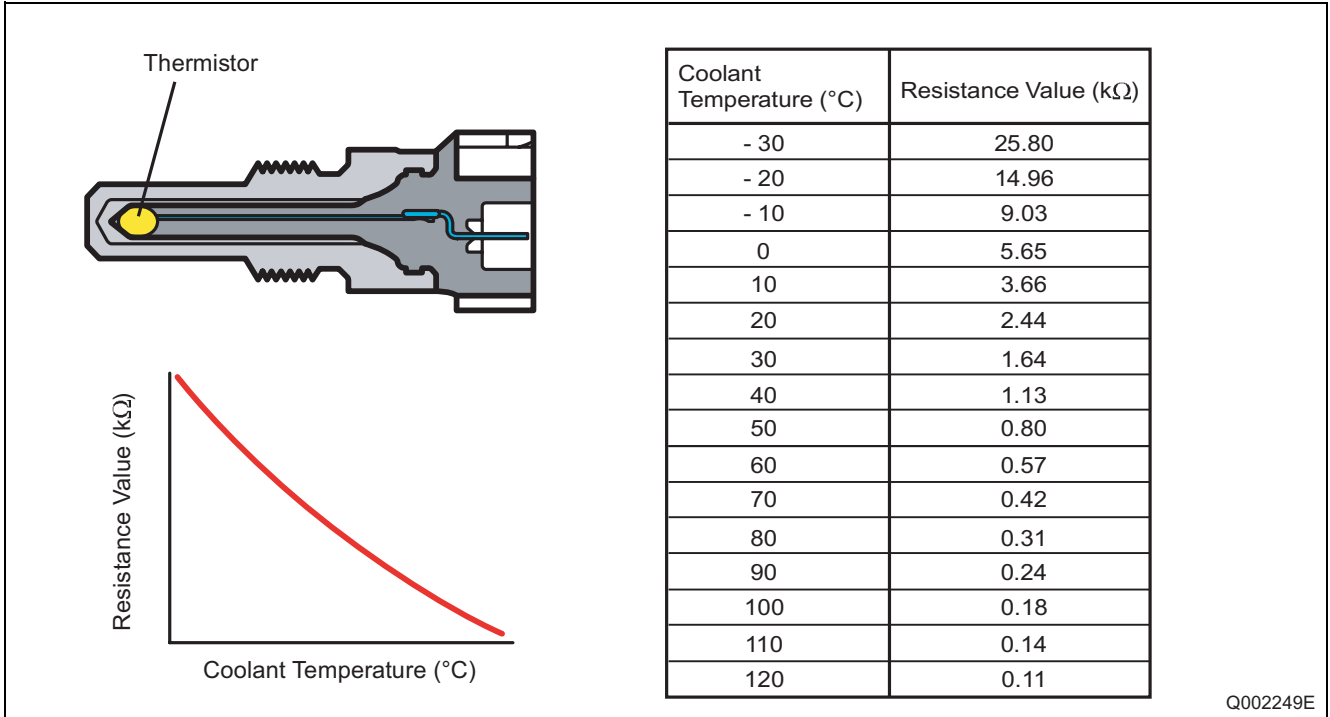

5.5 Exhaust Gas Recirculation (EGR) Valve

- The EGR valve is a linear solenoid type valve. The amount of EGR valve lift is changed according to signals from the engine ECU, to control the volume of exhaust gas sent to the intake manifold.

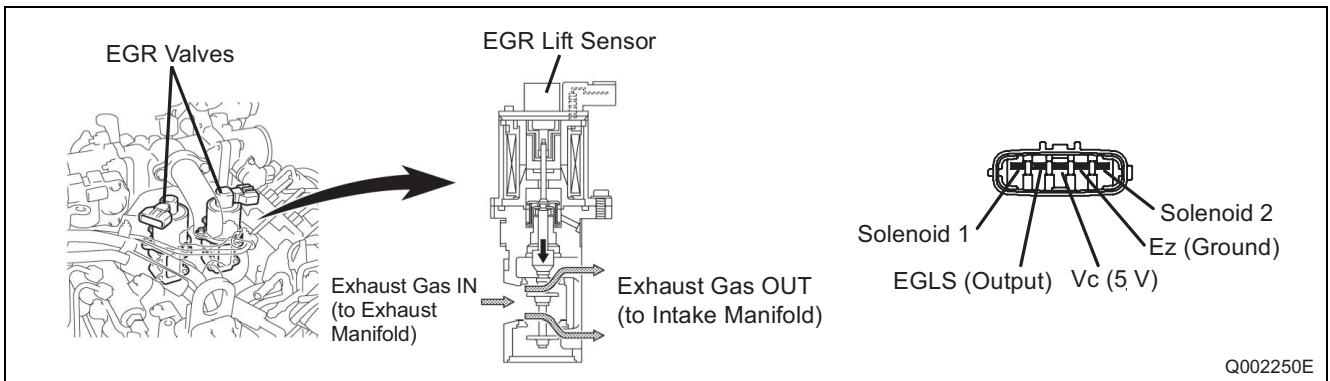

6. FUEL INJECTION CONTROL

6.1 Outline

- Fuel injection control can be roughly divided into the following four types of control: 1) Fuel injection quantity control, 2) fuel injection timing control, 3) fuel injection rate control, 4) fuel injection pressure control. Basic control content is identical to that contained in the general edition manual. However, the injection pattern is different for the LAND CRUISER (200 series). The following is an explanation of the injection pattern.

6.2 Injection Pattern

- Fuel injection timing is controlled according to the duration the injector is energized. First, main injection timing is determined, followed by timing determinations for pilot injections 1 and 2.

Start-Up (After Warm-Up)

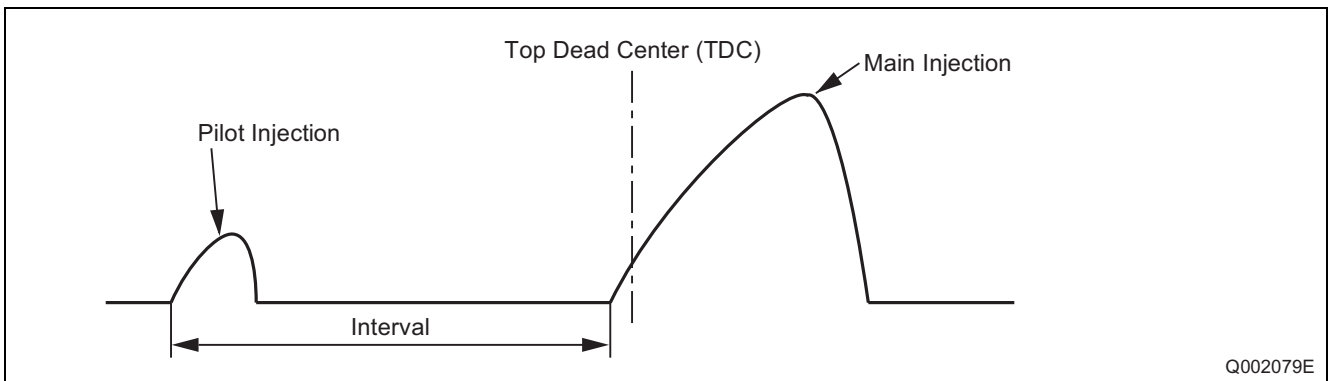

Start-Up (When at Low Temperature), Normal Operation

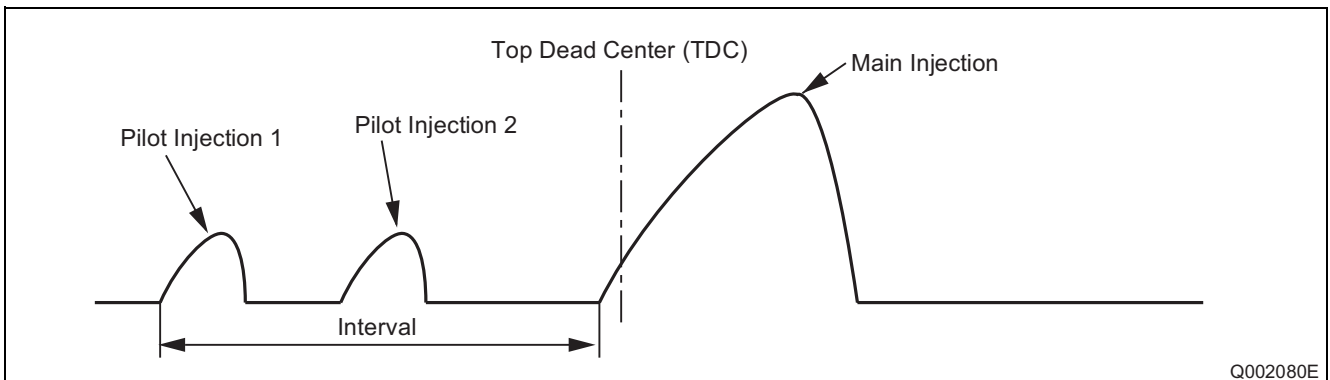

7. ENGINE ECU DIAGNOSTIC TROUBLE CODES (DTC)

7.1 DTC Table

DTC		Detection Item	MIL ON/OFF
SAE	TCCS		
P00AF	34	Turbocharger/Supercharger Boost Control "A" Malfunction	ON
P00B0		Turbocharger/Supercharger Boost Control "B" Malfunction	ON
P004B		Turbocharger/Supercharger Boost Control "B" Circuit Range	ON
P004C		Turbocharger/Supercharger Boost Control "B" Circuit Low	ON
P004D		Turbocharger/Supercharger Boost Control "B" Circuit High	ON
P0046		Turbocharger/Supercharger Boost Control "A" Circuit Range	ON
P0047		Turbocharger/Supercharger Boost Control "A" Circuit Low	ON
P0048		Turbocharger/Supercharger Boost Control "A" Circuit High	ON
P0069	A5	Boost Pressure - Barometric Pressure Correlation Malfunction	ON
P0087	49	Fuel / Rail System Pressure Sensor - Too Low	ON
P0088	78	Fuel Rail/System Pressure - Too High	ON
P0093		Fuel System Leak Detected - Large Leak	ON
P0100	31	Mass Air Flow (MAF) Meter Circuit Malfunction	ON
P0101		MAF Meter Circuit Range/Performance Problem	ON
P0102		MAF Meter Circuit Low Input	ON
P0103		MAF Meter Circuit High Input	ON
P0105	35	Boost Pressure/Barometric Pressure Circuit	ON
P0106	31	Boost Pressure/Barometric Pressure Circuit Range/Performance Problem	ON
P0107	35	Boost Pressure/Barometric Pressure Circuit Low Input	ON
P0108		Boost Pressure/Barometric Pressure Circuit High Input	ON
P0110	24	Intake Air Temperature (IAT) Circuit	ON
P0112		IAT Circuit Low Input	ON
P0113		IAT Circuit High Input	ON
P0115	22	Coolant Temperature Sensor Circuit Malfunction	ON
P0116		Coolant Temperature Sensor Circuit Range/Performance Problem	ON
P0117		Coolant Temperature Sensor Circuit Low Input	ON
P0118		Coolant Temperature Sensor Circuit High Input	ON
P0122	41	Throttle/Accelerator Position Sensor/Switch "A" Circuit Low Input	ON
P0123		Throttle/Accelerator Position Sensor/Switch "A" Circuit High Input	ON
P0168	39	Fuel Temperature Too High	ON
P0180	39	Fuel Temperature Sensor "A" Circuit	ON
P0182		Fuel Temperature Sensor "A" Circuit Low Input	ON
P0183		Fuel Temperature Sensor "A" Circuit High Input	ON

DTC		Detection Item	MIL ON/OFF
SAE	TCCS		
P0190	49	Rail Pressure Sensor Circuit Malfunction	ON
P0192		Rail Pressure Sensor Circuit Low Input	ON
P0193		Rail Pressure Sensor Circuit High Input	ON
P0222	41	Throttle/Accelerator Position Sensor/Switch "B" Circuit Low Input	ON
P0223		Throttle/Accelerator Position Sensor/Switch "B" Circuit High Input	ON
P0299	34	Turbocharger/Supercharger UnderBoost	ON
P0335	13, 12	Crankshaft Position Sensor "A" Circuit	ON
P0339	13	Crankshaft Position Sensor "A" Circuit Intermittent	OFF
P0340	12	Cylinder Recognition Sensor "A" Circuit (Bank 1 or Single Sensor)	ON
P0400	71	Exhaust Gas Recirculation (EGR) Flow Malfunction	ON
P0405	96	EGR Sensor "A" Circuit Low	ON
P0406		EGR Sensor "A" Circuit High	ON
P0407		EGR Sensor "B" Circuit Low	ON
P0408		EGR Sensor "B" Circuit High	ON
P0488, P213B	15	EGR Throttle Position Control Range/Performance	ON
P0500	42	Vehicle Speed Sensor Malfunction (MT)	ON
	21	Vehicle Speed Sensor Malfunction	-
P0503	23	Vehicle Speed Sensor Malfunction (Power Flicker, Noise)	-
P0504	51	Brake Switch "A"/"B" Correlation	OFF
P0560	96	System Voltage	ON
P0571	52	Stop Light Switch Circuit Malfunction	-
P0607	89	IC Circuit Malfunction	ON
	54	Stop Light Switch Signal Circuit	-
		Cancel Circuit Malfunction	-
	56	System Circuit Malfunction	-
P0617	43	Starter Relay Circuit High	ON
P0627	78	Fuel Pump Control Circuit/Open	ON
P062D	97	Fuel Injector Driver Circuit Performance Bank 1	ON
P062E		Fuel Injector Driver Circuit Performance Bank 2	ON
P1229	78	Fuel Pump System	ON
P1238		Injector Malfunction	ON
P1248	71	EGR Flow Bank 2	ON
P1251	34	Turbocharger/Supercharger OverBoost Condition (Too High)	ON
P1258		Turbocharger/Supercharger Boost Control Position Sensor "B" Circuit Range/Performance	ON
P1259		Turbocharger/Supercharger Boost Control Position Sensor 1 "B" Circuit Low	ON
P1260		Turbocharger/Supercharger Boost Control Position Sensor 1 "B" Circuit High	ON
P1262		Turbocharger/Supercharger Boost Control Position Sensor 2 "B" Circuit Low	ON
P1263		Turbocharger/Supercharger Boost Control Position Sensor 2 "B" Circuit High	ON

DTC		Detection Item	MIL ON/OFF
SAE	TCCS		
P1495	23	IAT Sensor 1 Circuit	ON
P1496		IAT Sensor 1 Circuit Low	ON
P1497		IAT Sensor 1 Circuit High	ON
P1601	89	Injector Correction Circuit Malfunction (EEPROM)	ON
P1604	00	Poor Start Judgment	OFF
P1605	00	Instable Idle	OFF
P1611	17	IC Circuit Malfunction	ON
P2120	19	Accelerator Position Sensor Circuit Malfunction (Open/Short)	ON
P2121		Throttle/Accelerator Position Sensor/Switch "D" Circuit	ON
P2122		Throttle/Accelerator Position Sensor/Switch "D" Circuit Low Input	ON
P2123		Throttle/Accelerator Position Sensor/Switch "D" Circuit High Input	ON
P2125		Throttle/Accelerator Position Sensor/Switch "E" Circuit	ON
P2127		Throttle/Accelerator Position Sensor/Switch "E" Circuit Low Input	ON
P2128		Throttle/Accelerator Position Sensor/Switch "E" Circuit High Input	ON
P2138		Throttle/Accelerator Position Sensor/Switch "D"/"E" Voltage Correlation	ON
P2226	A5	Barometric Pressure Circuit	ON
P2228		Barometric Pressure Circuit Low Input	ON
P2229		Barometric Pressure Circuit High Input	ON
P2563	34	Turbocharger/Supercharger Boost Control Position Sensor "A" Circuit Range	ON
P2564		Turbocharger/Supercharger Boost Control Position Sensor 1 "A" Circuit Low	ON
P2565		Turbocharger/Supercharger Boost Control Position Sensor 1 "A" Circuit High	ON
P2588		Turbocharger/Supercharger Boost Control Position Sensor 2 "A" Circuit Low	ON
P2589		Turbocharger/Supercharger Boost Control Position Sensor 2 "A" Circuit High	ON
B2799	99	Immobilizer ECU Communication Abnormality	ON
B276A		Immobilizer Communication Signal Stuck on High Side	ON
B279C		Linking Abnormality between Immobilizer ECU and Engine ECU	ON
U0101	A2	High Speed CAN Communication Performance	ON

8. ATTACHED MATERIALS

8.1 Engine ECU External Wiring Diagram

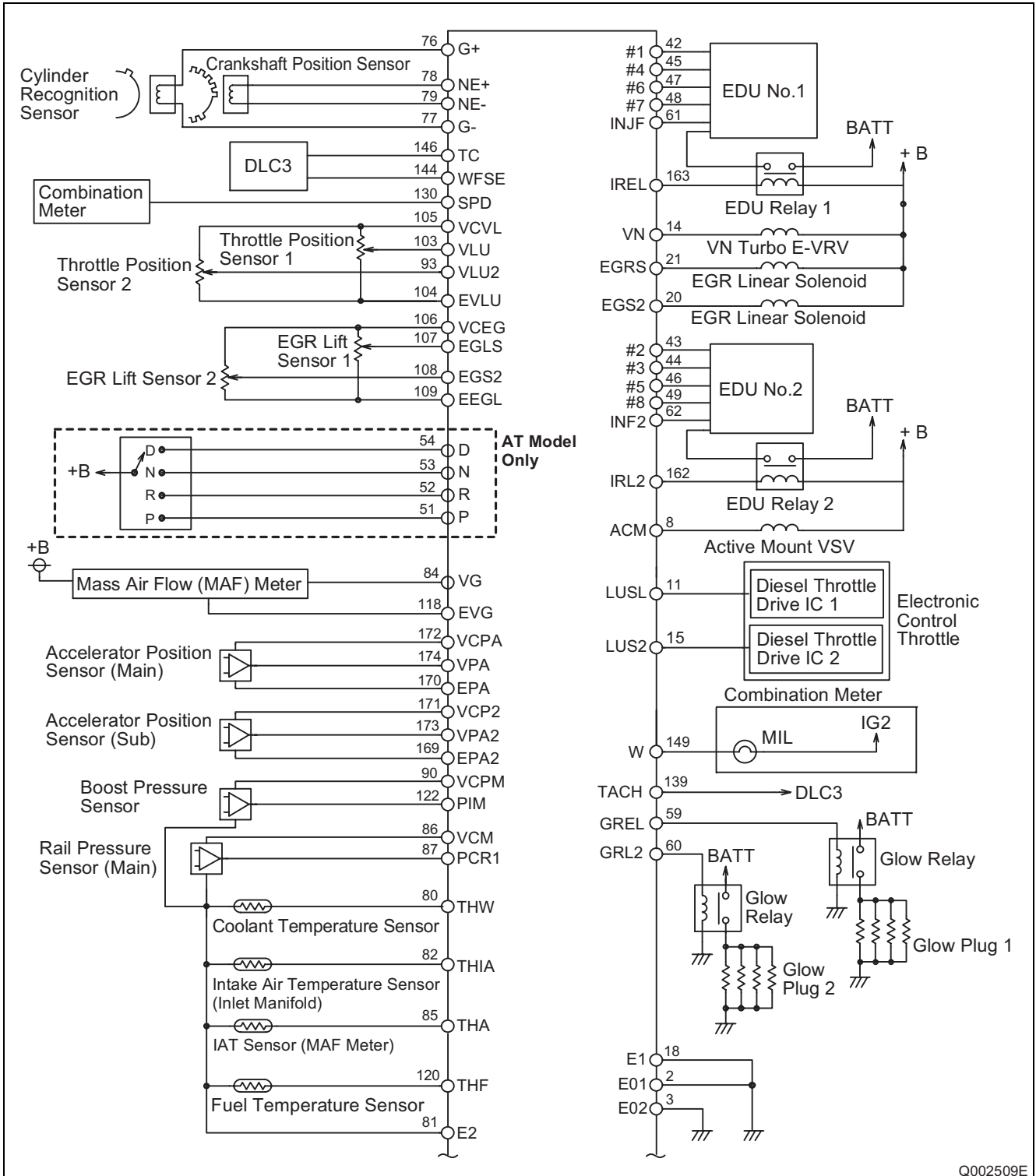

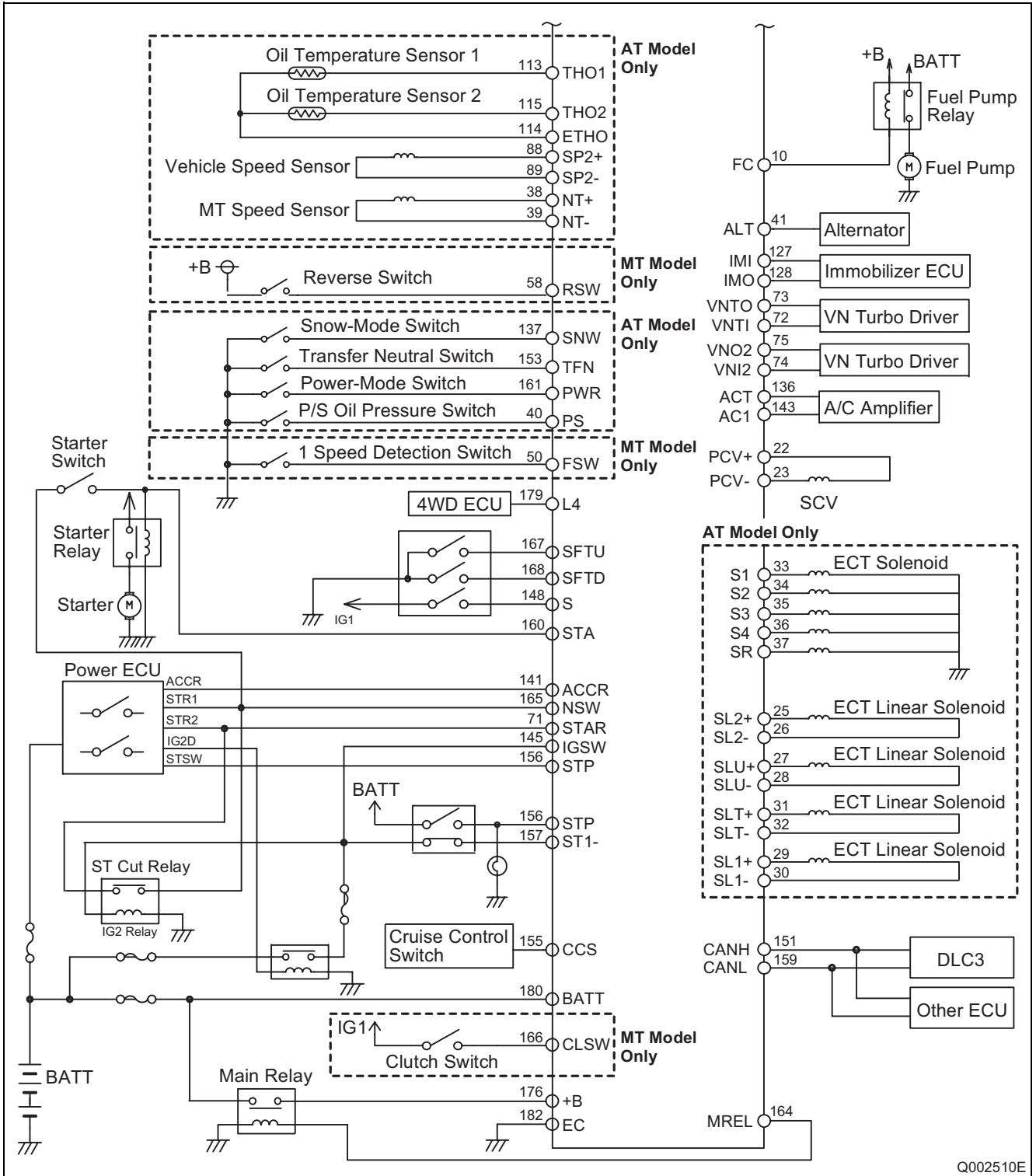

8.2 Connector Terminal Layout

275900-002#, -003#, -004#, -005#, -006# (AT model)

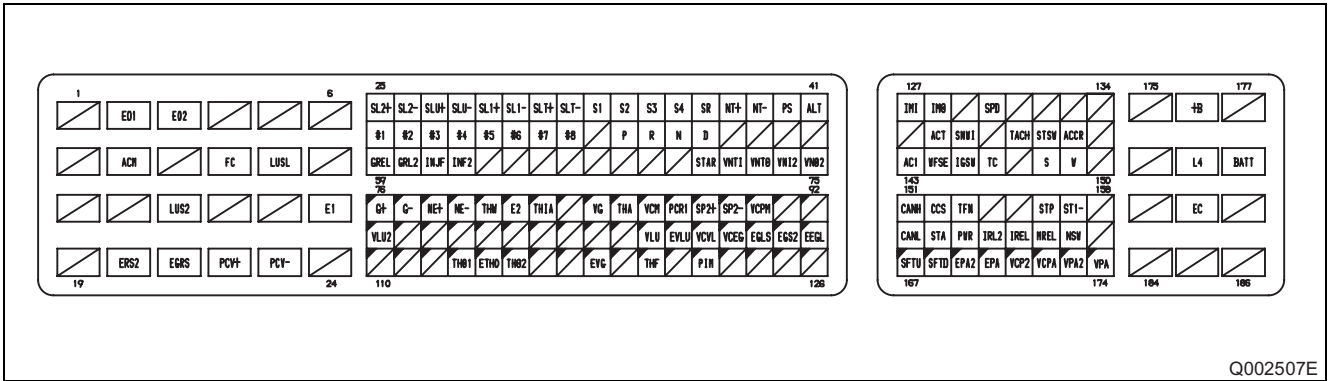

Q002507E

275900-007#, -008#, -009# (MT model)

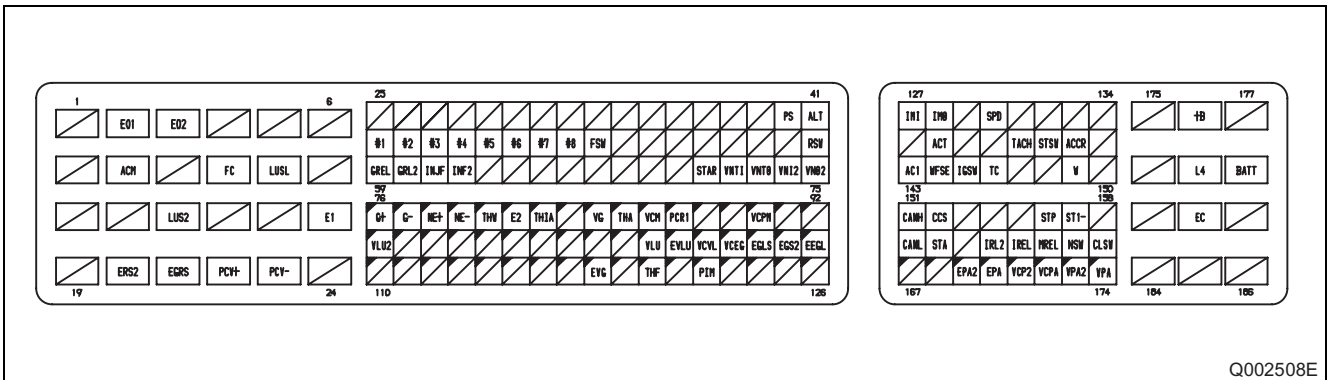

Q002508E

No.	Code	Terminal Description	Remarks
1	-	-	
2	E01	Engine Ground	
3	E02	Engine Ground	
4	-	-	
5	-	-	
6	-	-	
7	-	-	
8	ACM	Active Mount VSV	
9	-	-	
10	FC	-	
11	LUSL	Electronic Control Throttle Drive IC	
12	-	-	
13	-	-	
14	-	-	
15	LUS2	Electronic Control Throttle Drive IC	
16	-	-	
17	-	-	
18	E1	Engine Ground	
19	-	-	

No.	Code	Terminal Description	Remarks
20	ERS2	EGR Linear Solenoid	
21	ERSS	EGR Linear Solenoid	
22	PCV+	SCV	
23	PCV-	SCV	
24	-	-	
25	SL2+	ECT Linear Solenoid	295900-002#, -003#, 004#, -005#, -006# Only
26	SL2-	ECT Linear Solenoid	
27	SLU+	ECT Linear Solenoid	
28	SLU-	ECT Linear Solenoid	
29	SL1+	ECT Linear Solenoid	
30	SL1-	ECT Linear Solenoid	
31	SLT+	ECT Linear Solenoid	
32	SLT-	ECT Linear Solenoid	
33	S1	ECT Solenoid	
34	S2	ECT Solenoid	
35	S3	ECT Solenoid	
36	S4	ECT Solenoid	
37	SR	ECT Solenoid	
38	NT+	MT Speed Sensor +	
39	NT-	MT Speed Sensor -	
40	PS	Power Steering Pressure Switch	
41	ALT	Alternator	
42	#1	EDU	
43	#2	EDU	
44	#3	EDU	
45	#4	EDU	
46	#5	EDU	
47	#6	EDU	
48	#7	EDU	
49	#8	EDU	
50	FSW	1 Speed Detection Switch	295900-007#, -008#, 009# Only
51	P	-	295900-002#, -003#, 004#, -005#, -006# Only
52	R	-	
53	N	-	
54	D	-	
55	-	-	
56	-	-	
57	-	-	
58	RSW	Reverse Switch	295900-007#, -008#, 009# Only
59	GREL	Glow Relay	
60	GRL2	Glow Relay	

No.	Code	Terminal Description	Remarks
61	INJF	EDU	
62	INF2	EDU	
63	PRD	-	Internal to the Engine ECU
64	-	-	
65	-	-	
66	-	-	
67	-	-	
68	-	-	
69	-	-	
70	-	-	
71	STAR	Starter Relay	
72	VNTI	VN Turbo Driver 1	
73	VNTO	VN Turbo Driver 1	
74	VNI2	VN Turbo Driver 2	
75	VNO2	VN Turbo Driver 2	
76	G+	Cylinder Recognition Sensor +	
77	G-	Cylinder Recognition Sensor -	
78	NE+	Crankshaft Position Sensor +	
79	NE-	Crankshaft Position Sensor -	
80	THW	Coolant Temperature Sensor	
81	E2	Sensor Ground	
82	THIA	IAT Sensor (with Built-In Intake Manifold)	
83	-	-	
84	VG	MAF Meter 1	
85	THA	IAT Sensor (with Built-In MAF meter)	
86	VCM	Rail Pressure Sensor Power Supply	
87	PCR1	Rail Pressure Sensor	
88	SP2+	Vehicle Speed Sensor +	295900-002#, -003#, 004#, -005#, -006# Only
89	SP2-	Vehicle Speed Sensor -	
90	VCPM	Boost Pressure Sensor Power Supply	
91	-	-	
92	-	-	
93	VLU2	Throttle Position Sensor	
94	-	-	
95	-	-	
96	-	-	
97	-	-	
98	-	-	
99	-	-	
100	-	-	
101	VG2	-	Internal to the Engine ECU

No.	Code	Terminal Description	Remarks
102	THA2	-	Internal to the Engine ECU
103	VLU	Throttle Position Sensor	
104	EVLU	Throttle Position Sensor Ground	
105	VCVL	Throttle Position Sensor Power Supply	
106	VCEG	EGR Lift Sensor Power Supply	
107	EGLS	EGR Lift Sensor 1	
108	EGS2	EGR Lift Sensor 2	
109	EEGL	EGR Lift Sensor Ground	
110	-	-	
111	-	-	
112	-	-	
113	THO1	Oil Temperature Sensor 1	295900-002#, -003#, 004#, -005#, -006# Only
114	ETHO	Oil Temperature Sensor Ground	
115	THO2	Oil Temperature Sensor 2	
116	-	-	
117	-	-	
118	EVG	MAF Meter (Ground)	
119	-	-	
120	THF	Fuel Temperature Sensor	
121	-	-	
122	PIM	Boost Pressure Sensor	
123	-	-	
124	-	-	
125	-	-	
126	-	-	
127	IMI	Immobilizer ECU	
128	IMO	Immobilizer ECU	
129	-	-	
130	SPD	Vehicle Speed Sensor (Combination Meter)	
131	-	-	
132	-	-	
133	-	-	
134	-	-	
135	-	-	
136	ACT	A/C Amplifier	
137	SNWI	Snow-Mode Switch	295900-002#, -003#, 004#, -005#, -006# Only
138	-	-	
139	TACH	DLC3	
140	STSW	Engine ECU	
141	ACCR	Engine ECU	

No.	Code	Terminal Description	Remarks
142	-	-	
143	AC 1	A/C ECU	
144	WFSE	DLC3	
145	IGSW	Ignition Switch	
146	TC	Test Terminal	
147	-	-	
148	S	Shift Position Switch	295900-002#, -003#, 004#, -005#, -006# Only
149	W	Malfunction Indicator Lamp (MIL)	
150	GIND	Glow Indicator Light	
151	CANH	J/C	
152	CCS	Cruise Control Switch	
153	TFN	Transfer Neutral Switch	295900-002#, -003#, -004#, -005#, -006# Only
154	-	-	
155	-	-	
156	STP	Stop Light Switch	
157	ST1-	Stop Light Switch	
158	-	-	
159	CANL	DLC3, Other ECU	
160	STA	Starter Relay	
161	PWR	Pattern Select Switch	295900-002#, -003#, -004#, -005#, -006# Only
162	IRL2	Injector Relay 2	
163	IREL	Injector Relay 1	
164	MREL	Main Relay	
165	NSW	Neutral Start Switch	
166	CLSW	Clutch Switch	295900-007#, -008#, 009# Only
167	SFTU	Sport-Shift Switch	295900-002#, -003#, -004#, -005#, -006# Only
168	SFTD	Sport-Shift Switch	
169	EPA2	Accelerator Position Sensor (Sub) Ground	
170	EPA	Accelerator Position Sensor (Main) Ground	
171	VCP2	Accelerator Position Sensor (Sub) Power Supply	
172	VCPA	Accelerator Position Sensor (Main) Power Supply	
173	VPA2	Accelerator Position Sensor Sub	
174	VPA	Accelerator Position Sensor Main	
175	-	-	
176	+B	Battery + Main Relay 1	
177	-	-	
178	-	-	
179	L4	4WD ECU	
180	BATT	Battery	

No.	Code	Terminal Description	Remarks
181	-	-	
182	EC	Case Ground	
183	-	-	
184	-	-	
185	-	-	
186	-	-	

Published : September 2007

Edited and published by:

DENSO CORPORATION

Service Department

1-1 Showa-cho, Kariya, Aichi Prefecture, Japan