

DENSO

Diesel Injection Pump

SERVICE MANUAL

**Common Rail System for
TOYOTA HILUX / KIJYANG INNOVA /
INNOVA 1KD/2KD
OPERATION**

July, 2004

DENSO CORPORATION

00400077

© 2004 DENSO CORPORATION

All Rights Reserved. This book may not be reproduced or copied, in whole or in part, without the written permission of the publisher.

TABLE OF CONTENTS

1. PRODUCT APPLICATION LIST	1
1-1. PRODUCT APPLICATION LIST	1
2. OUTLINE	3
2-1. OUTLINE OF SYSTEM	3
2-2. SYSTEM CONFIGURATION	5
3. CONSTRUCTION AND OPERATION	9
3-1. DESCRIPTION OF MAIN COMPONENTS	9
3-2. DESCRIPTION OF CONTROL SYSTEM COMPONENTS	23
3-3. EGR CONTROL SYSTEM	37
3-4. DIESEL THROTTLE (ELECTRONICALLY CONTROLLED INTAKE AIR THROTTLE MECHANISM)	39
3-5. FUEL FILTER WARNING	40
4. DIAGNOSIS SYSTEM	43
4-1. DESCRIPTION	43
4-2. DTC CHECK/CLEAR	45
4-3. CHECK MODE PROCEDURE	47
4-4. DTC (DIAGNOSTIC TROUBLE CODE) CHART	48
4-5. FAIL-SAFE CHART	54
4-6. EXTERNAL WIRING DIAGRAM	58

1. PRODUCT APPLICATION LIST

1-1. PRODUCT APPLICATION LIST

Vehicle Name	Vehicle Model	Engine Model	Exhaust Volume	Reference
HILUX/KIJYANG INNOVA/INNOVA 1KD-FTV	KUN15R, KUN16R	1KD-FTV	3.0L	IMV; Since August, 2004
HILUX/KIJYANG INNOVA/INNOVA 2KD-FTV	KUN10R, KUN25R, KUN26R, KUN40R	2KD-FTV	2.5L	IMV; Since August, 2004

Vehicle Name	Part Type	DENSO Part Number	Car Manufacturer Part Number	Reference	
HILUX/KIJYANG INNOVA/INNOVA 1KD-FTV	Supply pump	SM294000-0350	221000L020	HP3	
	Injector	SM095000-5442	236700L020		
	Rail	SM095440-0551	238100L010		
	NE sensor	029600-1151	90919-05050		
	TDC sensor	029600-0630	90919-05025		
	Coolant temperature sensor	179700-0451	89422-33030		
	Fuel temperature sensor	179730-0020	89454-60010-B		
	Turbo pressure sensor	079800-7470	89421-71020		
	Air flow meter	VN197400-4000	-		
	Engine ECU		MA175800-6590	896610K200	
			MA175800-6600	896610K210	
			MA175800-6610	896610K220	
			MA175800-6650	896610K250	
			MA175800-6640	896610K260	
			MA175800-6630	896610K290	
			MA175800-6620	896610K300	
			MA175800-6660	896610K310	
			MA175800-6670	896610K320	
			MA175800-6680	896610K330	
			MA175800-6710	896610K340	
			MA175800-6720	896610K350	
			MA175800-6690	896610K360	
		MA175800-6670	896610K370		
	EDU		101310-5441	8987071011	
			101310-5481	8987071021	
	EGR valve	VN101397-1000	258000L010		
	Accelerator pedal module	198800-3140	7812009010		

Vehicle Name	Part Type	DENSO Part Number	Car Manufacturer Part Number	Reference
HILUX/KIJYANG INNOVA/INNOVA 2KD-FTV	Supply pump	SM294000-0350	221000L020	HP3
	Injector	SM095000-5520	236700L010	
	Rail	SM095440-0551	238100L010	
	NE sensor	029600-1151	90919-05050	
	TDC sensor	029600-0630	90919-05025	
	Coolant temperature sensor	179700-0451	89422-33030	
	Fuel temperature sensor	179730-0020	89454-60010-B	
	Turbo pressure sensor	079800-7470	89421-71020	
	Air flow meter	VN197400-4000	-	
	Engine ECU	MA175800-6800	896610K390	
		MA175800-6740	896610K400	
		MA175800-6760	896610K410	
		MA175800-6780	896610K440	
		MA175800-6790	896610K450	
		MA175800-6730	896610K460	
		MA175800-6750	896610K470	
		MA175800-6770	896610K480	
		MA175800-6830	896610K490	
		MA175800-6850	896610K500	
	MA175800-6870	896610K530		
	EDU	101310-5441	8987071011	
		101310-5481	8987071021	
EGR valve	VN101397-0990	258000L020		
Accelerator pedal module	198800-3140	7812009010		

2. OUTLINE

2-1. OUTLINE OF SYSTEM

- The common rail system was developed primarily to cope with exhaust gas regulations for diesel engines, and aimed for 1. further improved fuel economy; 2. noise reduction; and 3. high power output.
- This Common Rail System meets the Step III Stage of the European Emission Regulations as shown in the figure on the right.

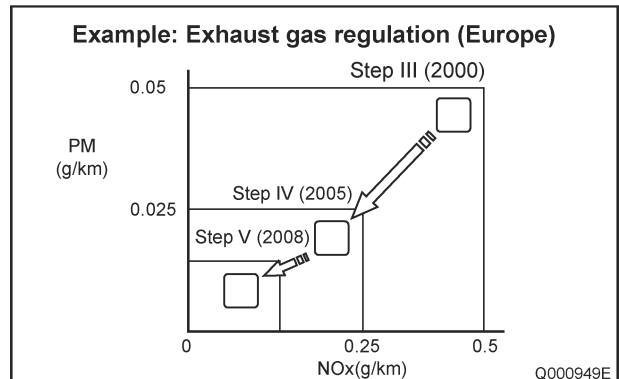

A. System Characteristics:

The common rail system uses a type of accumulation chamber called a rail to store pressurized fuel, and injectors that contain electronically controlled solenoid valves to spray the pressurized fuel into the cylinders. Because the engine ECU controls the injection system (including the injection pressure, injection rate, and injection timing), the system is unaffected by the engine speed or load. This ensures a stable injection pressure at all times, particularly in the low engine speed range, and dramatically decreases the amount of black smoke ordinarily emitted by a diesel engine during start-up and acceleration. As a result, exhaust gas emissions are cleaner and reduced, and higher power output is achieved.

a. Injection Pressure Control

- Enables high-pressure injection, even in the low engine speed range.
- Optimizes control to minimize particulate matter and NOx emissions.

b. Injection Timing Control

Optimally controls the timing to suit driving conditions.

c. Injection Rate Control

Pilot injection control sprays a small amount of fuel before the main injection.

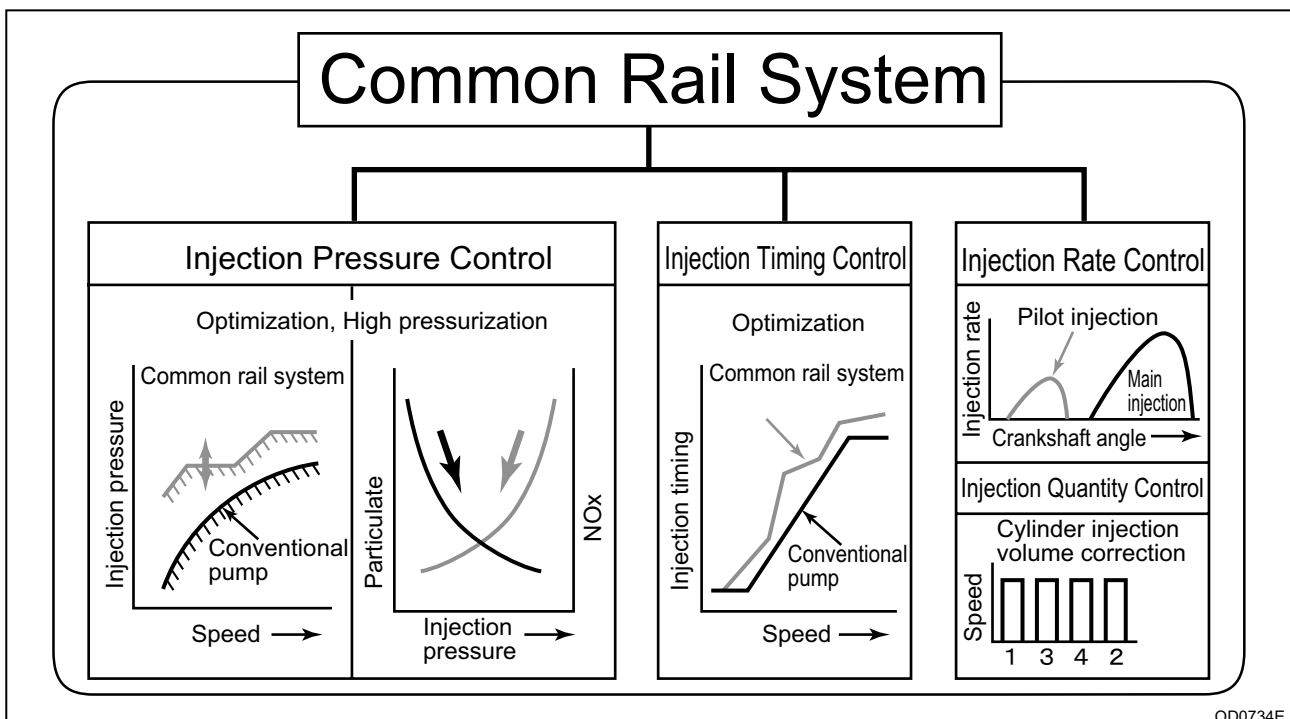

B. Comparison to the Conventional System

System	In-line, VE Pump	Common Rail System
Injection Quantity Control	Pump (Governor)	Engine ECU, Injector (TWV)*1
Injection Timing Control	Pump (Timer)	Engine ECU, Injector (TWV)*1
Rising Pressure	Pump	Engine ECU, Supply Pump
Distributor	Pump	Engine ECU, Rail
Injection Pressure Control	Dependent upon Speed and Injection Quantity	Engine ECU, Supply Pump (SCV)*2

*1 TWV: Two Way Valve *2 SCV: Suction Control Valve QD2341E

2-2. SYSTEM CONFIGURATION

A. Main System Components

a. Location (1)

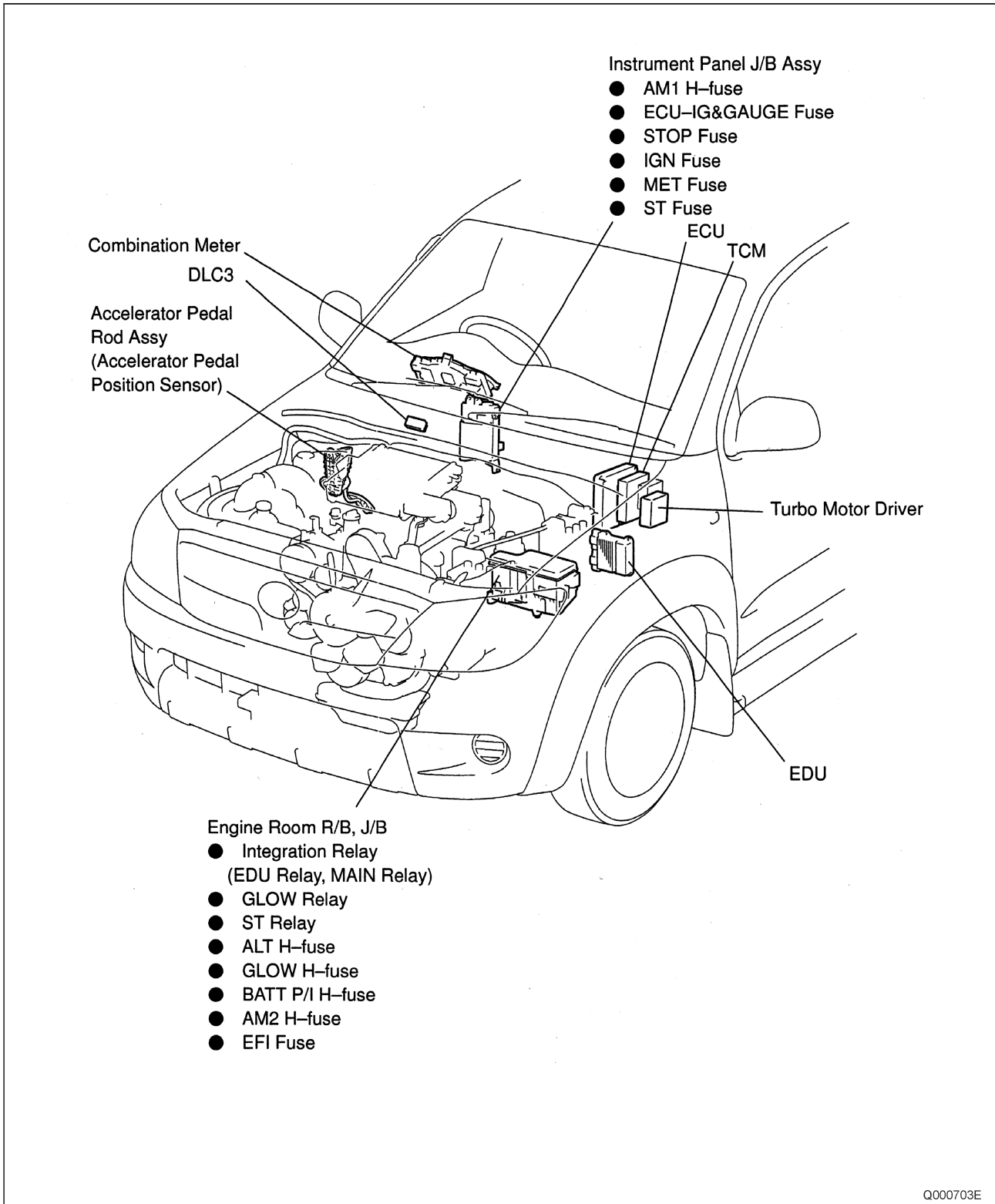

b. Location (2)

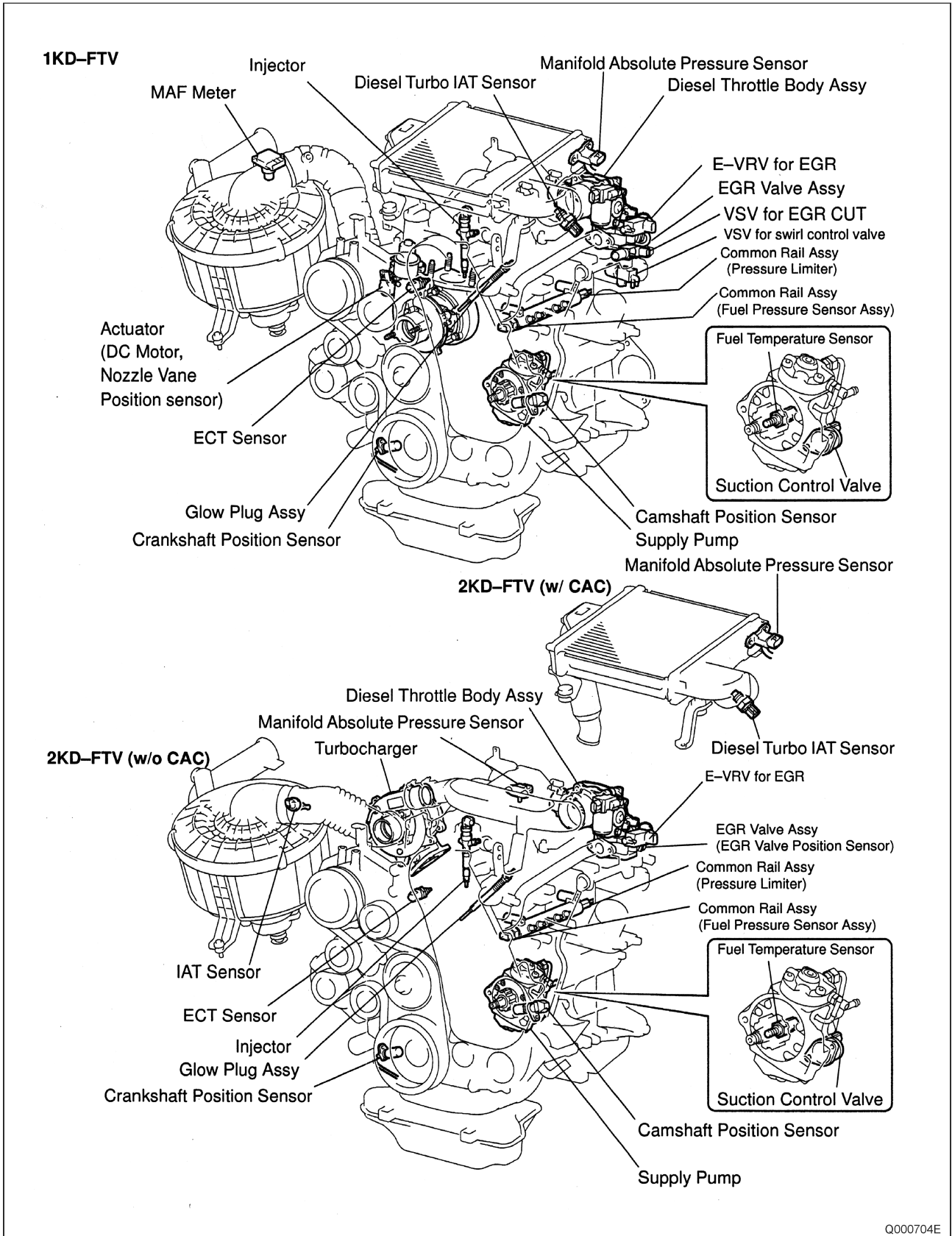

Q000704E

B. Outline of Composition and Operation

a. Composition

The common rail system consists primarily of a supply pump, rail, injectors, and engine ECU.

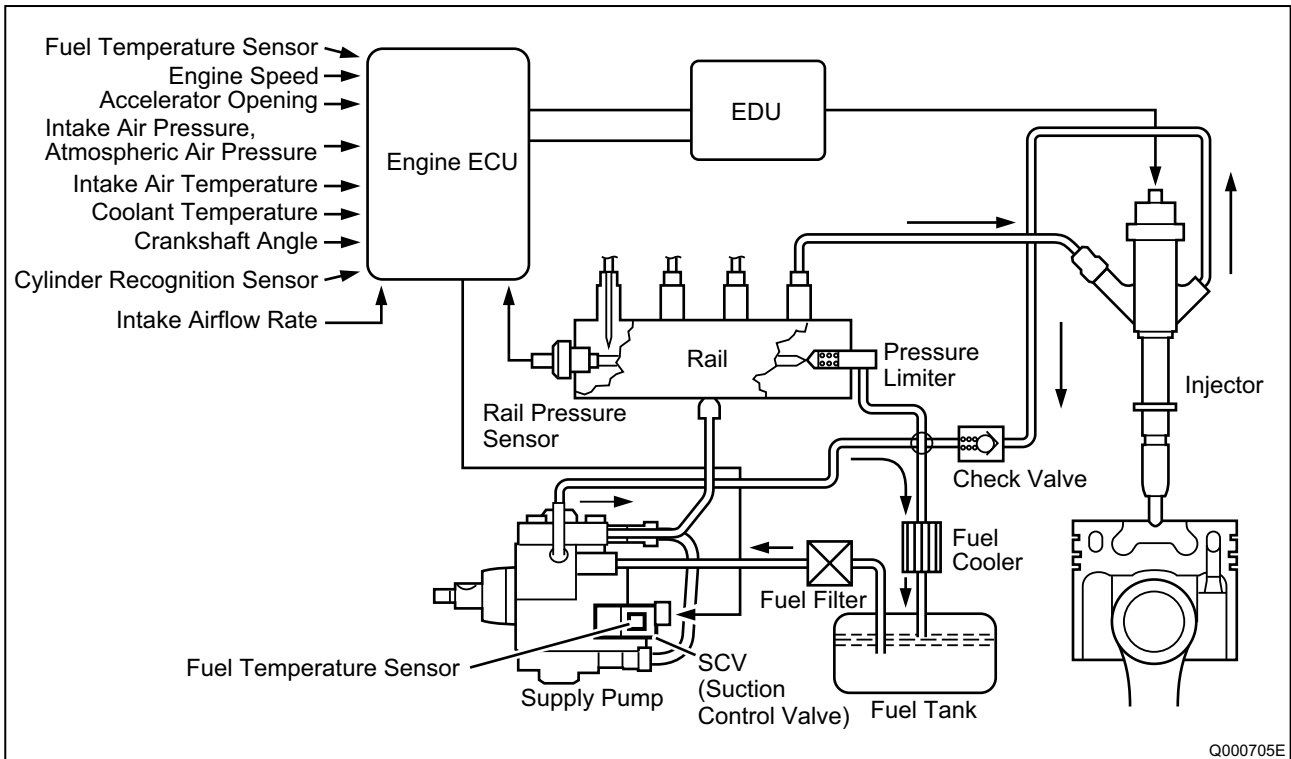

b. Operation

(1) Supply pump (HP3)

The supply pump draws fuel from the fuel tank, and pumps the high pressure fuel to the rail. The quantity of fuel discharged from the supply pump controls the pressure in the rail. The SCV (Suction Control Valve) in the supply pump effects this control in accordance with the command received from the ECU.

(2) Rail

The rail is mounted between the supply pump and the injector, and stores the high-pressure fuel.

(3) Injector (X2 revised type)

This injector replaces the conventional injection nozzle, and achieves optimal injection by effecting control in accordance with signals from the ECU. Signals from the ECU determine the length of time and the timing in which current is applied to the injector. This in turn, determines the quantity, rate and timing of the fuel that is injected from the injector.

(4) Engine ECU

The engine ECU calculates data received from the sensors to comprehensively control the injection quantity, timing and pressure, as well as the EGR (exhaust gas recirculation).

C. Fuel System and Control System

a. Fuel System

This system comprises the route through which diesel fuel flows from the fuel tank to the supply pump, via the rail, and is injected through the injector, as well as the route through which the fuel returns to the tank via the overflow pipe.

b. Control System

In this system, the engine ECU controls the fuel injection system in accordance with the signals received from various sensors. The components of this system can be broadly divided into the following three types: (1) Sensors; (2) ECU; and (3) Actuators.

(1) Sensors

Detect the engine and driving conditions, and convert them into electrical signals.

(2) Engine ECU

Performs calculations based on the electrical signals received from the sensors, and sends them to the actuators in order to achieve optimal conditions.

(3) Actuators

Operate in accordance with electrical signals received from the ECU. Injection system control is undertaken by electronically controlling the actuators. The injection quantity and timing are determined by controlling the length of time and the timing in which the current is applied to the TWV (Two-Way Valve) in the injector. The injection pressure is determined by controlling the SCV (Suction Control Valve) in the supply pump.

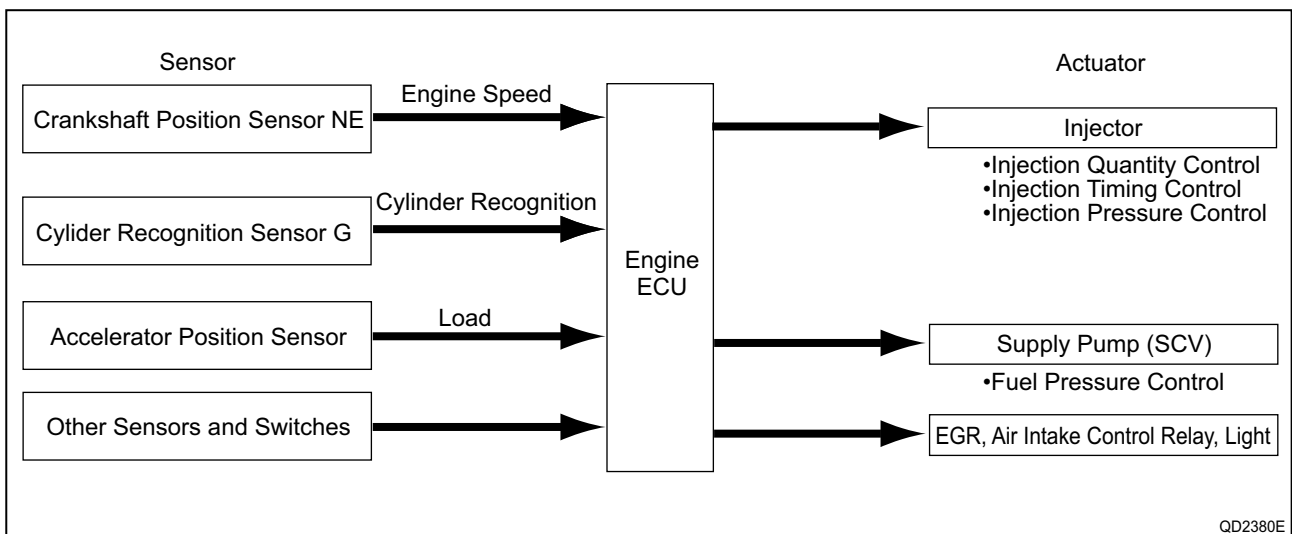

3. CONSTRUCTION AND OPERATION

3-1. DESCRIPTION OF MAIN COMPONENTS

A. Supply Pump (HP3)

a. Outline

- The supply pump consists primarily of the pump body (eccentric cam, ring cam, and plungers), SCV (Suction Control Valve), fuel temperature sensor, and feed pump.
- The two plungers are positioned vertically on the outer ring cam for compactness.
- The engine drives the supply pump at a ratio of 1:2. The supply pump has a built-in feed pump (trochoid type), and draws the fuel from the fuel tank, sending it to the plunger chamber.
- The internal camshaft drives the two plungers, and they pressurize the fuel sent to the plunger chamber and send it to the rail. The quantity of fuel supplied to the rail is controlled by the SCV, using signals from the engine ECU. The SCV is a normally closed type (the intake valve closes during de-energization).

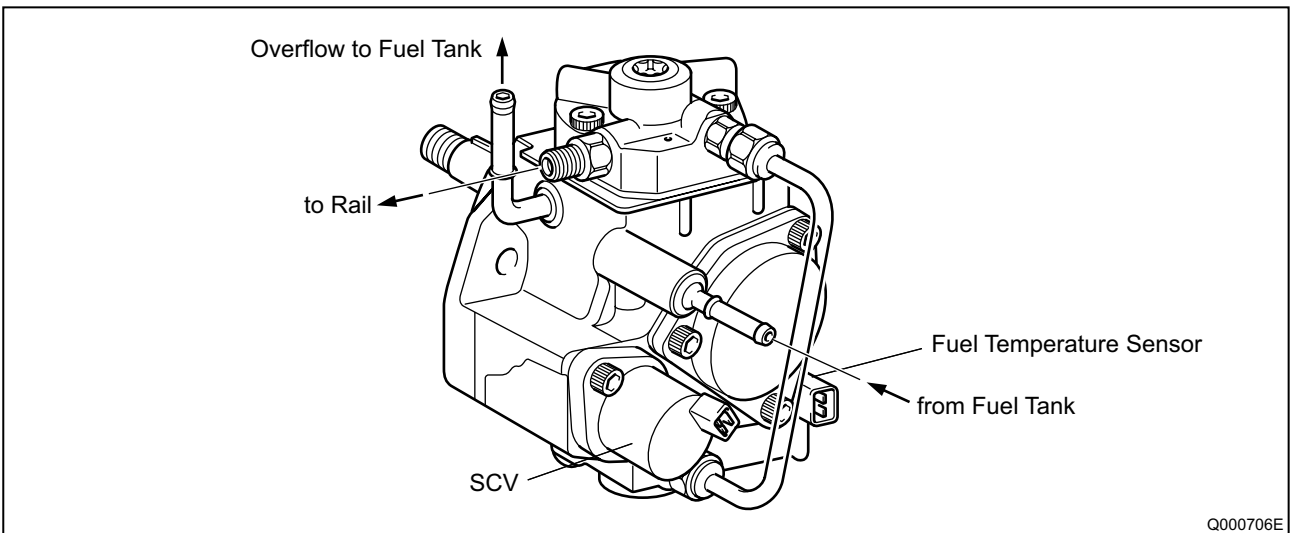

Q000706E

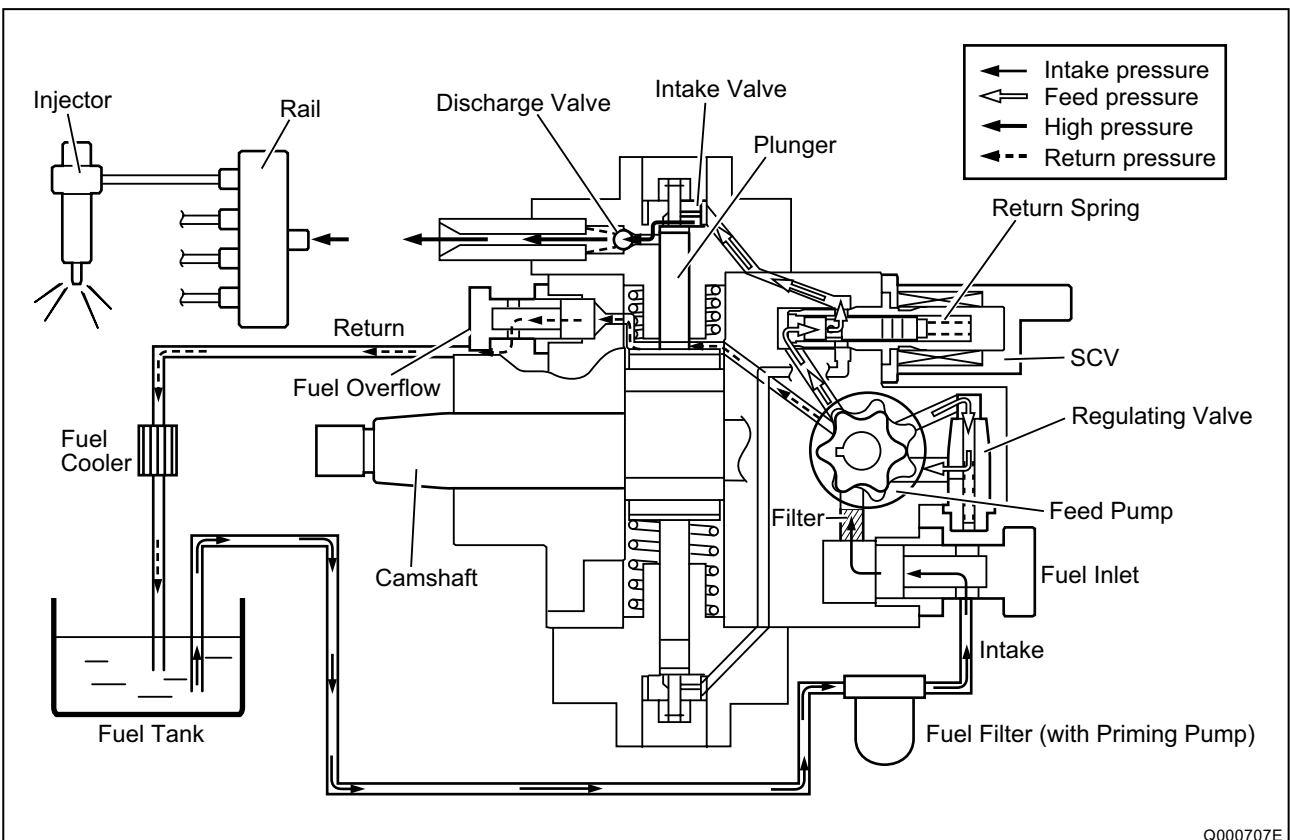

Q000707E

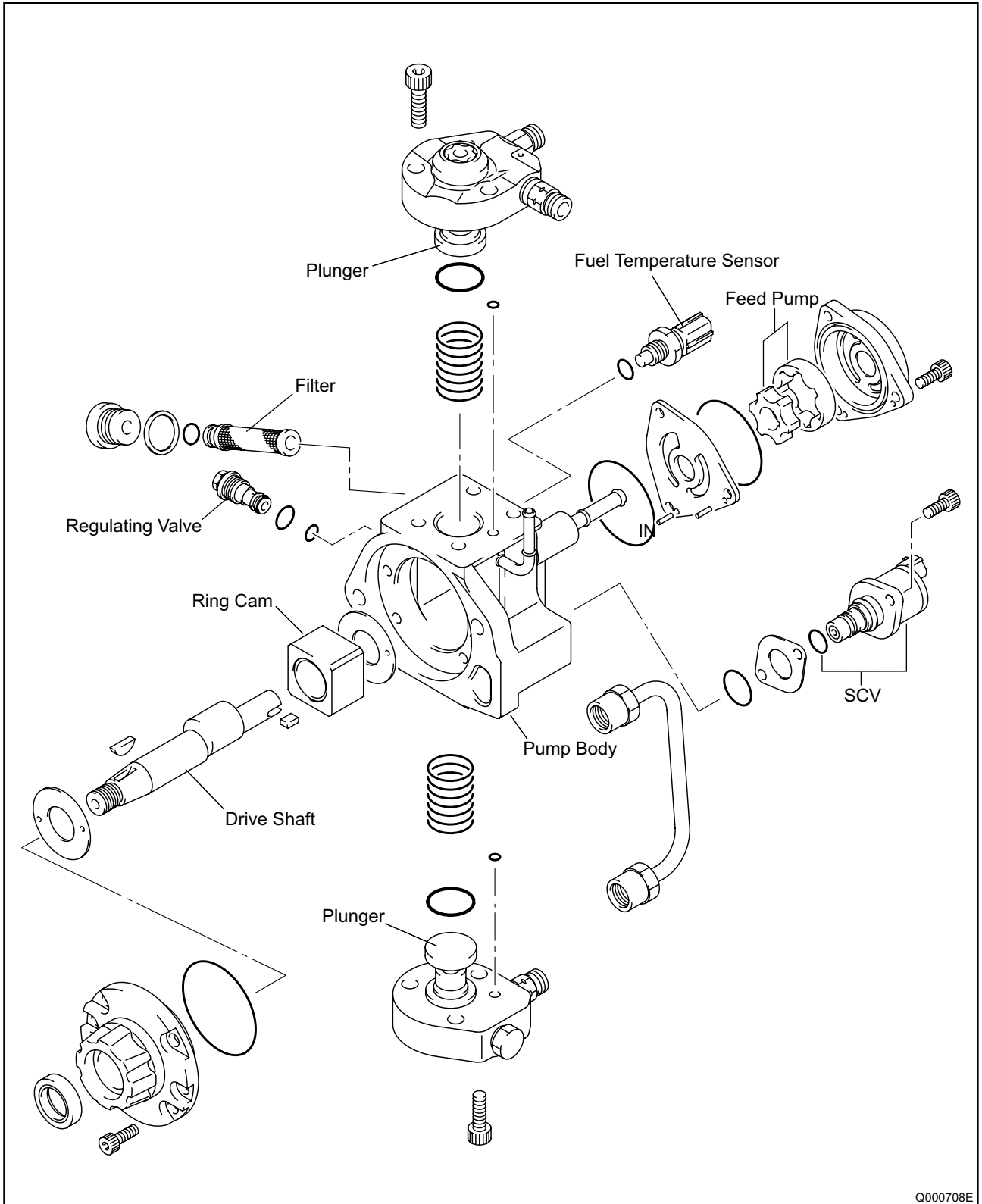

Q000708E

b. Supply Pump Internal Fuel Flow

The fuel that is drawn from the fuel tank passes through the route in the supply pump as illustrated, and is fed into the rail.

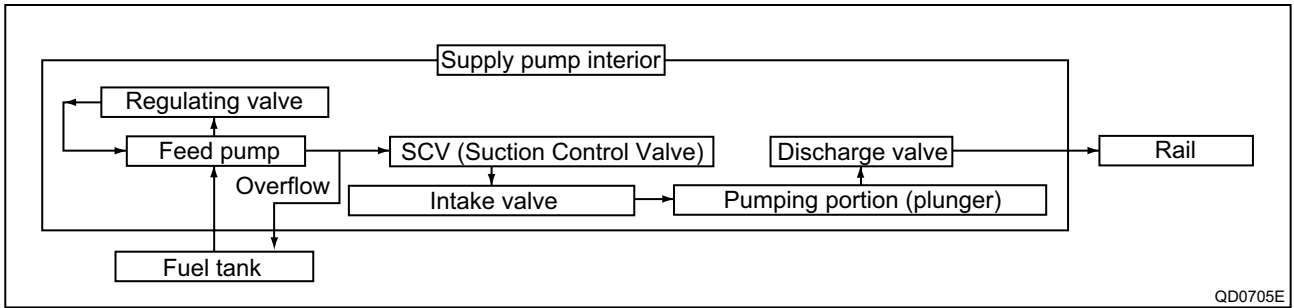

QD0705E

c. Construction of Supply Pump

The eccentric cam is attached to the drive shaft. The eccentric cam is connected to the ring cam.

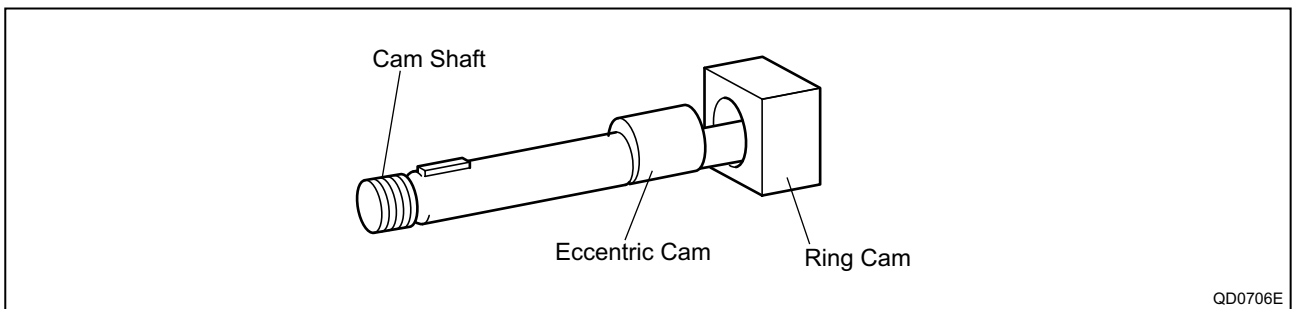

QD0706E

- As the drive shaft rotates, the eccentric cam rotates eccentrically, and the ring cam moves up and down while rotating.

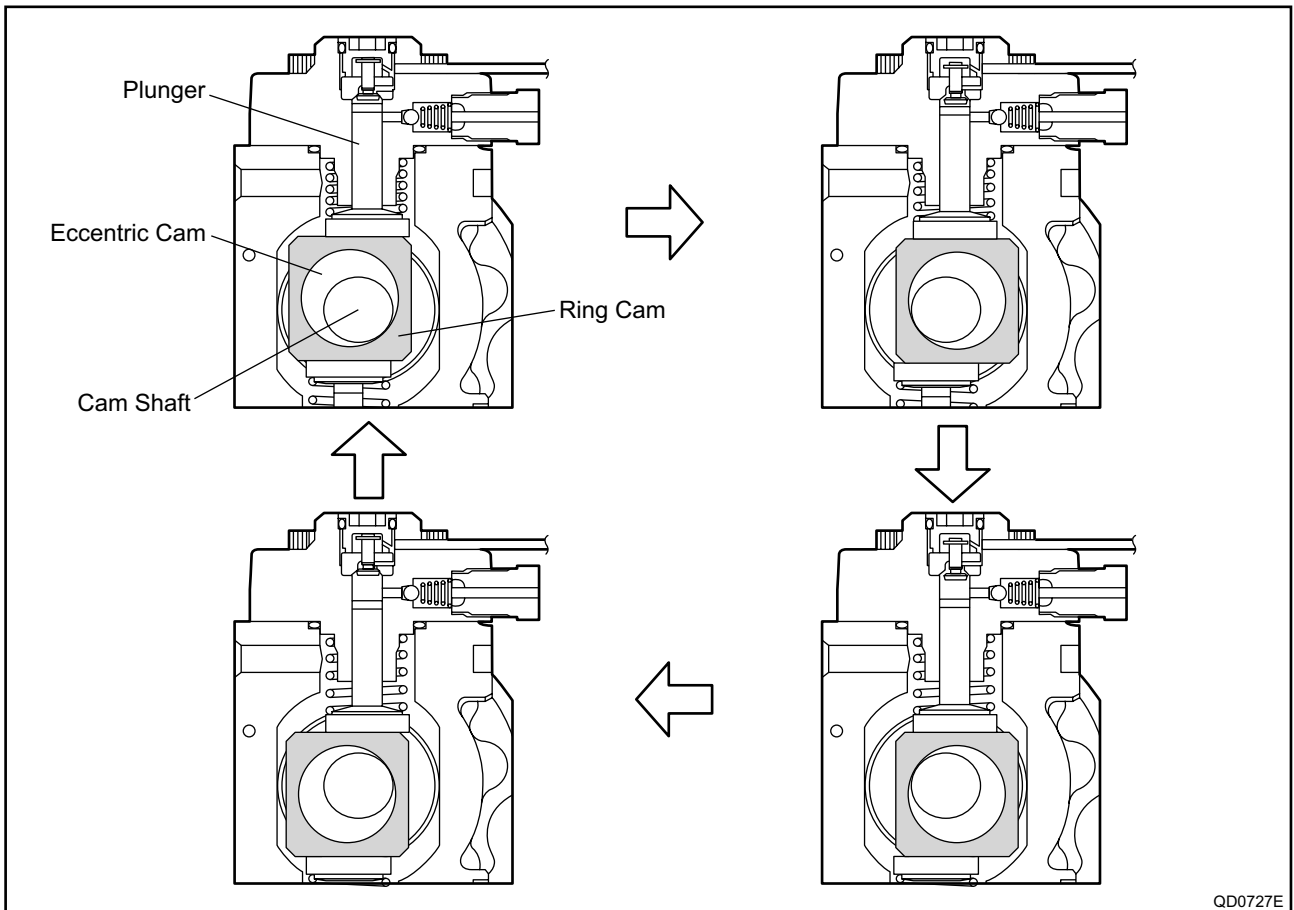

QD0727E

- The plunger and the suction valve are attached to the ring cam. The feed pump is connected to the rear of the drive shaft.

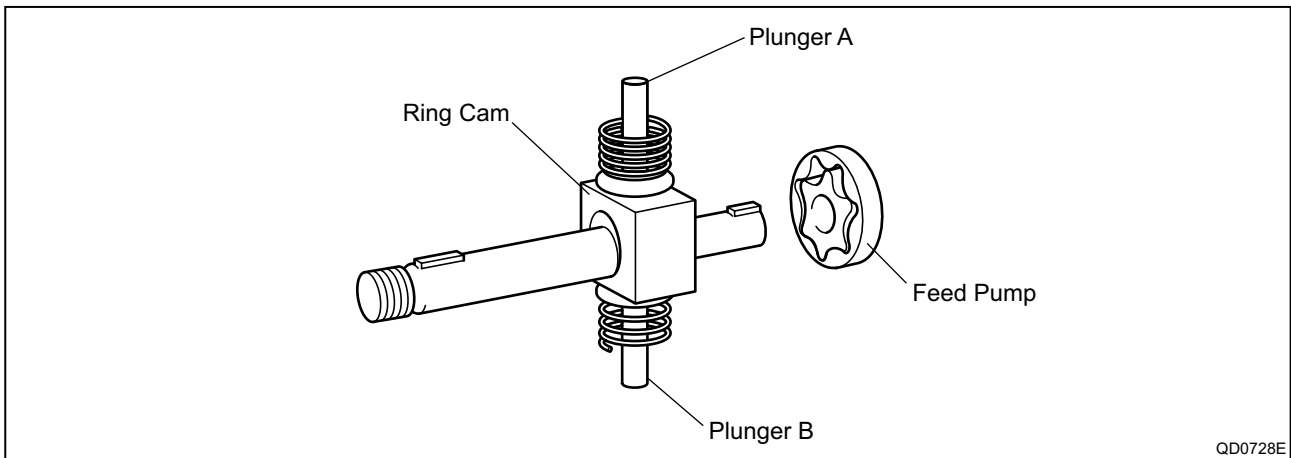

d. Operation of the Supply Pump

As shown in the illustration below, the rotation of the eccentric cam causes the ring cam to push Plunger A upwards. Due to the spring force, Plunger B is pulled in the opposite direction to Plunger A. As a result, Plunger B draws in fuel, while Plunger A pumps it to the rail.

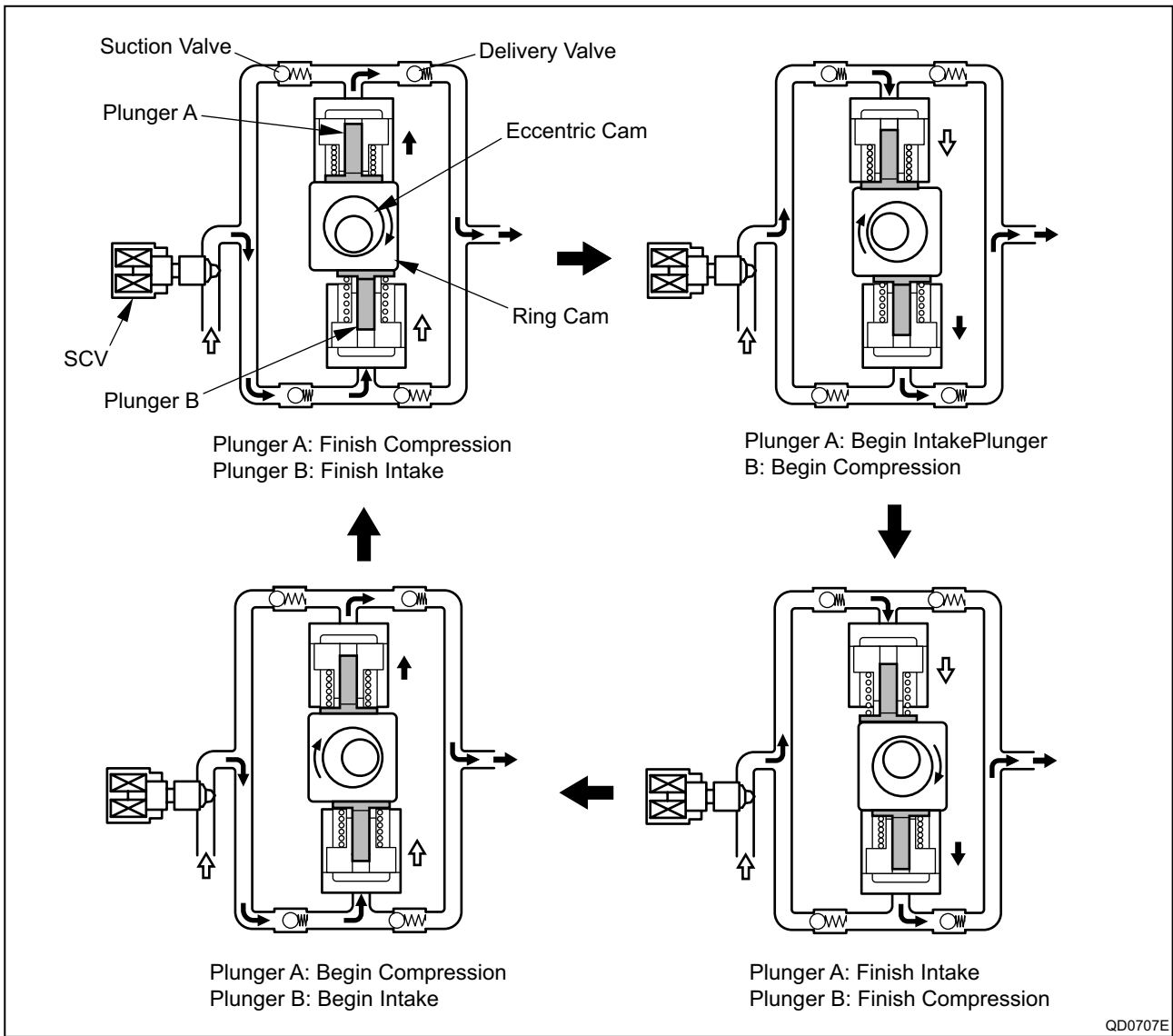

B. Description of Supply Pump Components

a. Feed Pump

The trochoid type feed pump, which is integrated in the supply pump, draws fuel from the fuel tank and feeds it to the two plungers via the fuel filter and the SCV (Suction Control Valve). The feed pump is driven by the drive shaft. With the rotation of the inner rotor, the feed pump draws fuel from its suction port and pumps it out through the discharge port. This is done in accordance with the space that increases and decreases with the movement of the outer and inner rotors.

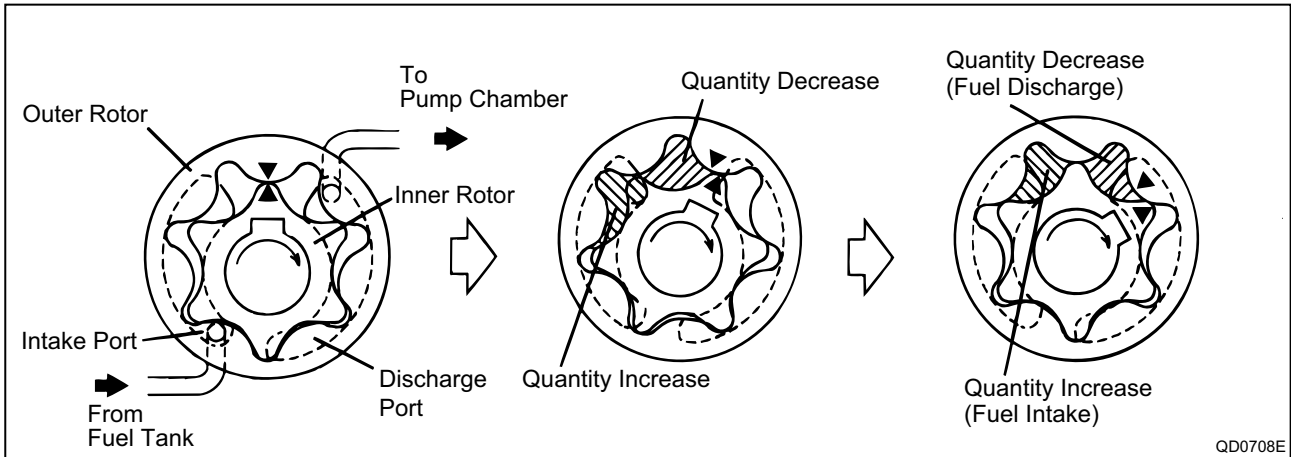

b. SCV: Suction Control Valve

- A linear solenoid type valve has been adopted. The ECU controls the duty ratio (the duration in which current is applied to the SCV), in order to control the quantity of fuel that is supplied to the high-pressure plunger.
- Because only the quantity of fuel that is required for achieving the target rail pressure is drawn in, the actuating load of the supply pump decreases.
- When current flows to the SCV, variable electromotive force is created in accordance with the duty ratio, moving the valve needle to the right side, and changing the opening of the fuel passage to regulate the fuel quantity.
- With the SCV ON, the valve spring contracts, completely opening the fuel passage and supplying fuel to the plungers. (Full quantity intake and full quantity discharge)
- When the SCV is OFF, the force of the valve spring moves the valve needle to the left, closing the fuel passage (normally closed).
- By turning the SCV ON/OFF, fuel is supplied in an amount corresponding to the actuation duty ratio, and fuel is discharged by the plungers.

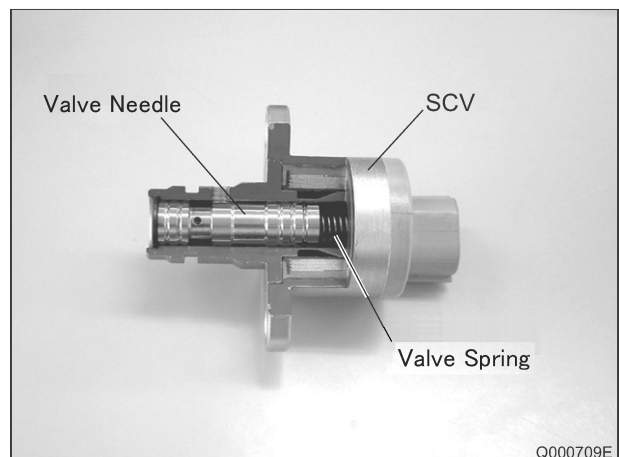

A) In case of long duty ON

Long duty ON => large valve opening => maximum intake quantity

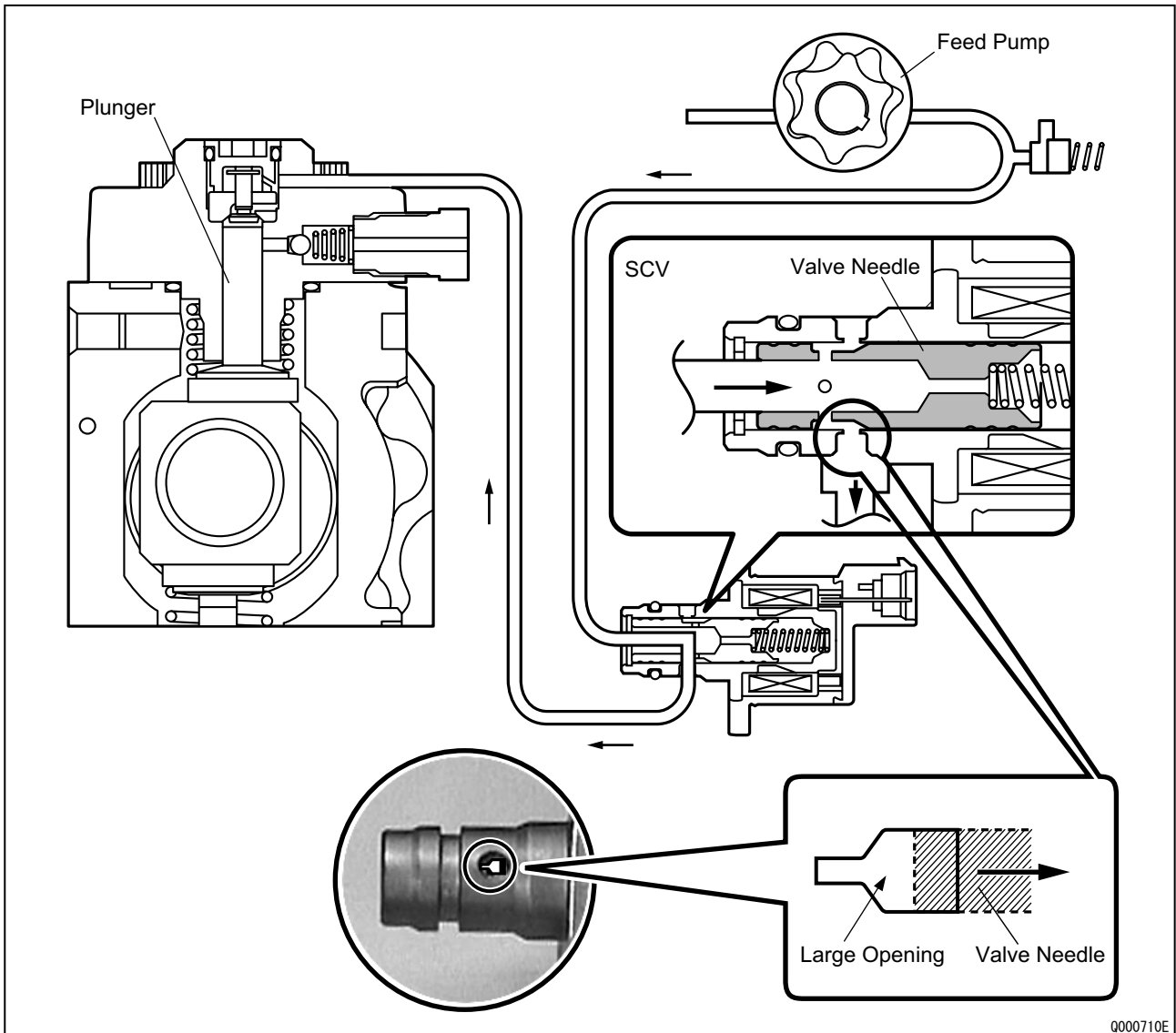

Q000710E

B) In case of short duty ON

Short duty ON => small valve opening => minimum intake quantity

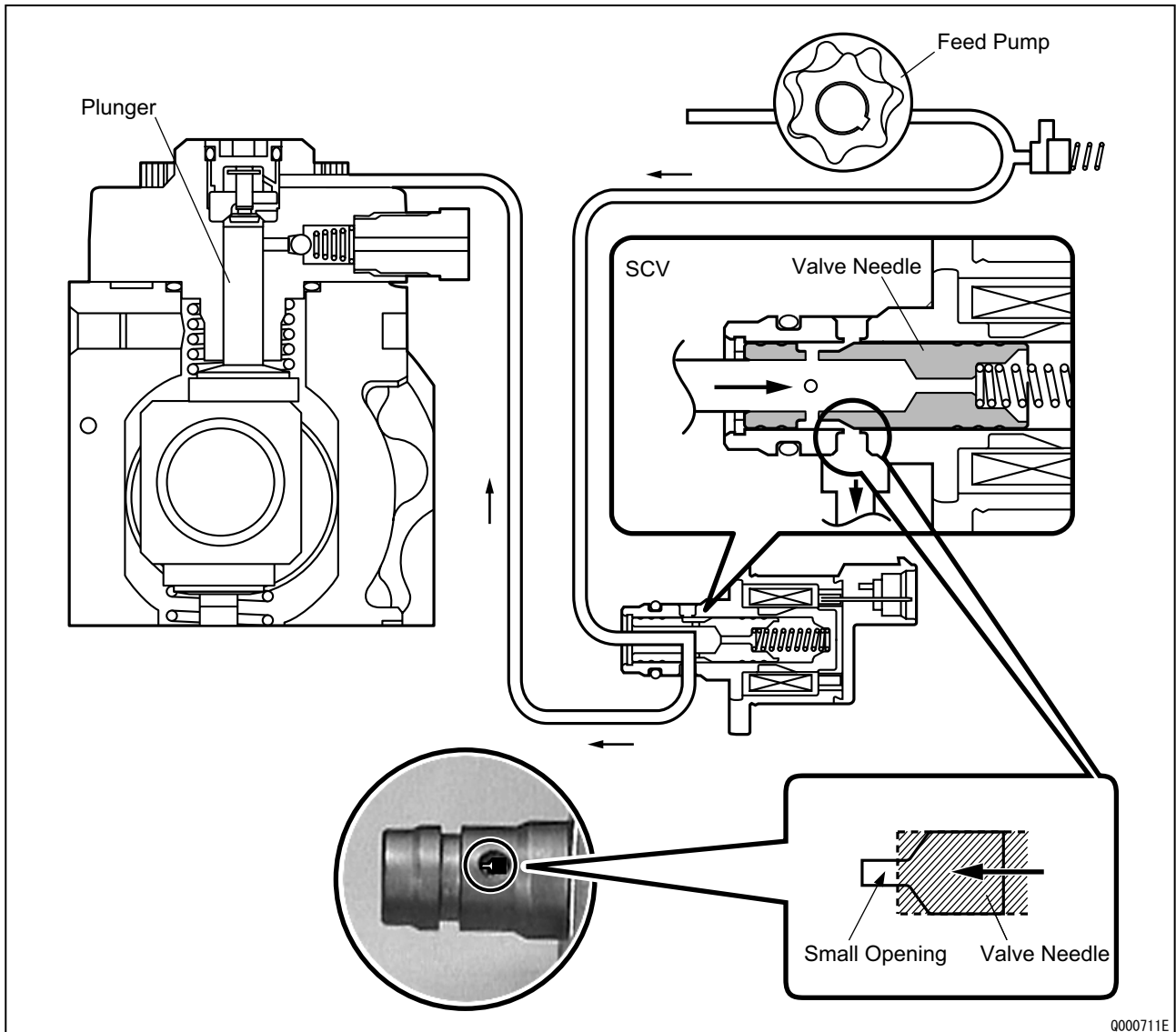

C. Rail

a. Outline

- Stores pressurized fuel (0 to 160 MPa) that has been delivered from the supply pump and distributes the fuel to each cylinder injector. A rail pressure sensor and a pressure discharge valve (low-pressure valve) are adopted in the rail.
- The rail pressure sensor (Pc sensor) detects fuel pressure in the rail and sends a signal to the engine ECU, and the pressure limiter controls the excess pressure. This ensures optimum combustion and reduces combustion noise.

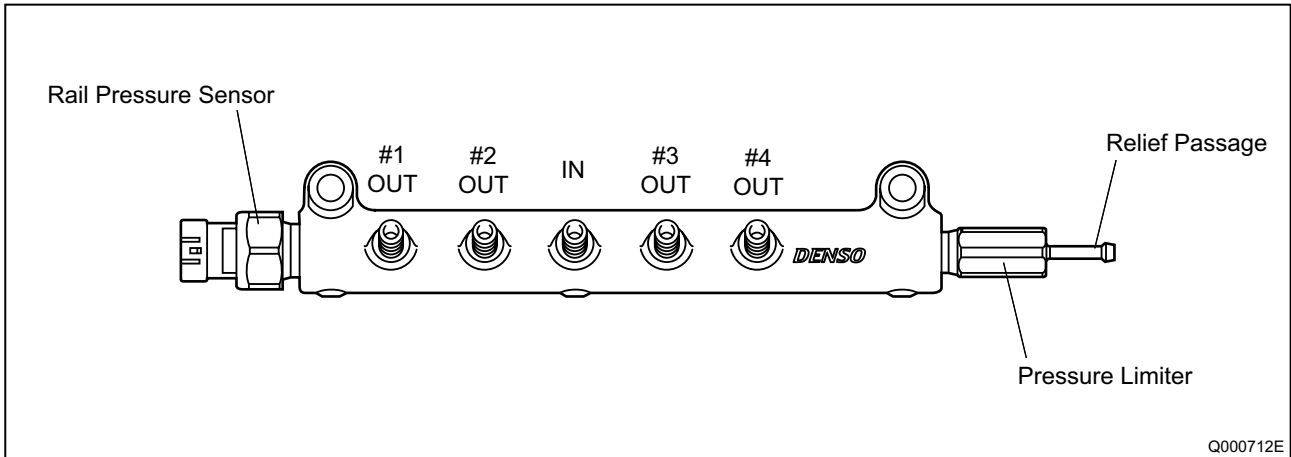

b. Pressure Limiter

The pressure limiter opens to release the pressure if an abnormally high pressure is generated.

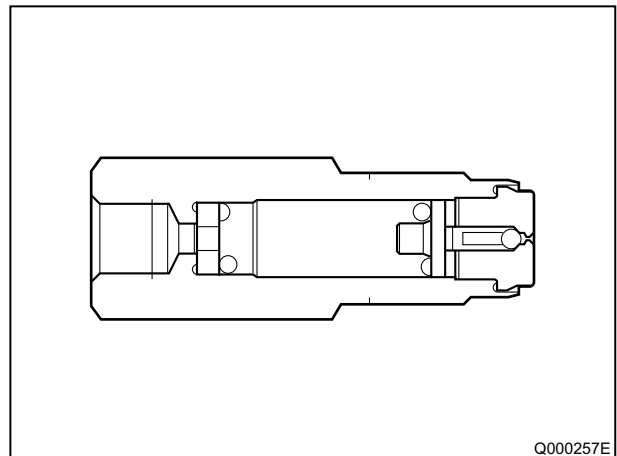

- When the rail pressure reaches approximately 200 MPa (2038 kg/cm²), it trips the pressure limiter (the valve opens). When the pressure drops to approximately 50 MPa (509.5 kg/cm²), the pressure limiter returns to its normal state (the valve closes) in order to maintain the proper pressure.

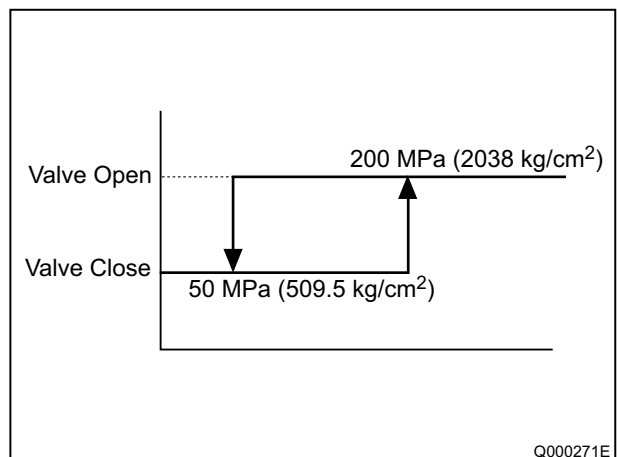

D. Injector (X2 revised type)

a. Outline

The injectors inject the high-pressure fuel from the rail into the combustion chambers at the optimum injection timing, rate, and spray condition, in accordance with commands received from the ECU.

A) Characteristics

- A compact, energy-saving solenoid-control type TWV (Two-Way Valve) injector has been adopted.
- QR codes displaying various injector characteristics and the ID codes showing these in numeric form (30 base 16 characters) are engraved on the injector head. The 1KD-FTV common rail system optimizes injection volume control using this information. When an injector is newly installed in a vehicle, it is necessary to enter the ID codes in the engine ECU using the DST-2.

b. Construction

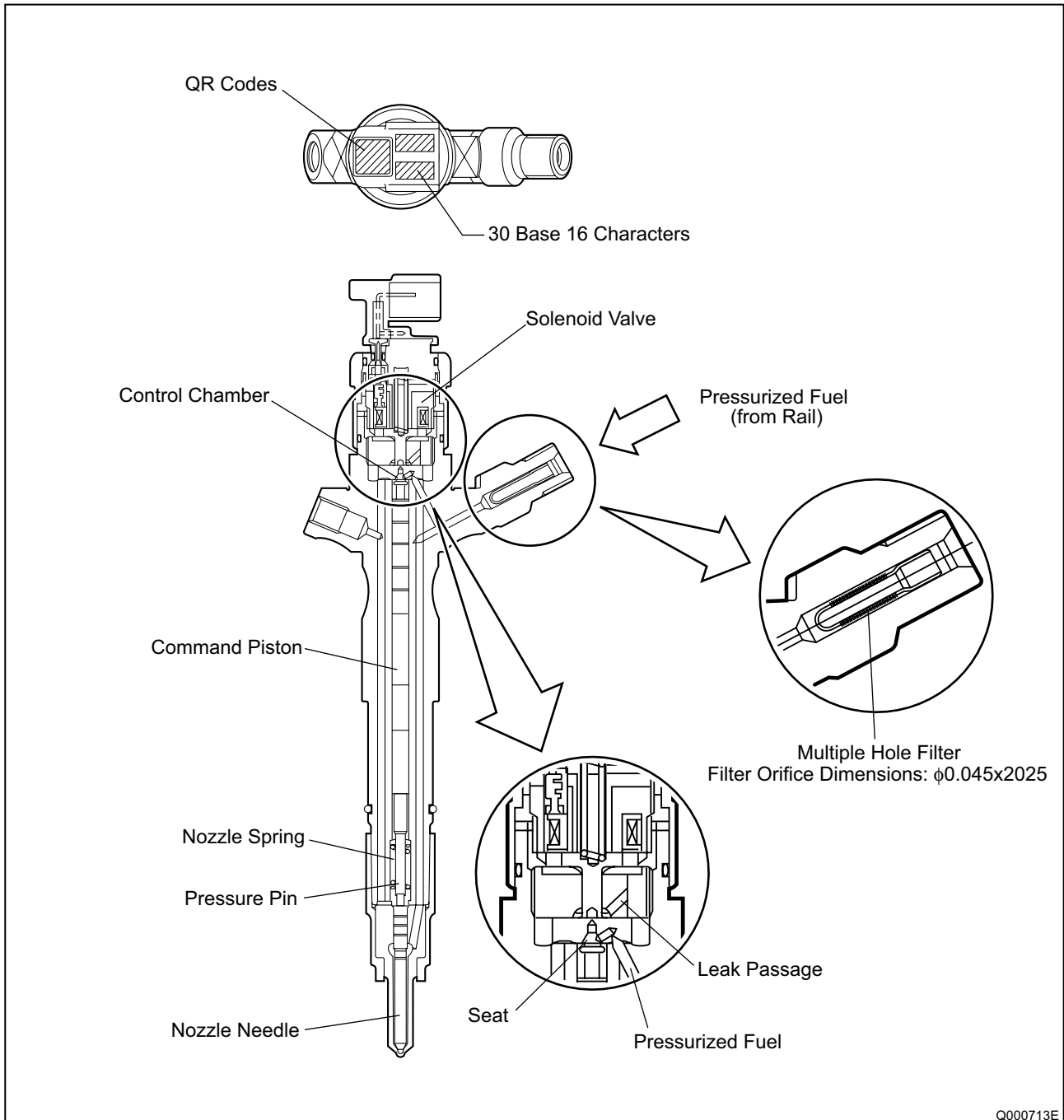

c. Operation

The TWV (Two-Way Valve) solenoid valve opens and closes the outlet orifice to control both the pressure in the control chamber, and the start and end of injection.

A) No injection

When no current is supplied to the solenoid, the spring force is stronger than the hydraulic pressure in the control chamber. Thus, the solenoid valve is pushed downward, effectively closing the outlet orifice. For this reason, the hydraulic pressure that is applied to the command piston causes the nozzle spring to compress. This closes the nozzle needle, and as a result, fuel is not injected.

B) Injection

- When current is initially applied to the solenoid, the attraction force of the solenoid pulls the solenoid valve up, effectively opening the outlet orifice and allowing fuel to flow out of the control chamber. After the fuel flows out, the pressure in the control chamber decreases, pulling the command piston up. This causes the nozzle needle to rise and the injection to start.
- The fuel that flows past the outlet orifice flows to the leak pipe and below the command piston. The fuel that flows below the piston lifts the piston needle upward, which helps improve the nozzle's opening and closing response.
- When current continues to be applied to the solenoid, the nozzle reaches its maximum lift, where the injection rate is also at the maximum level. When current to the solenoid is turned OFF, the solenoid valve falls, causing the nozzle needle to close immediately and the injection to stop.

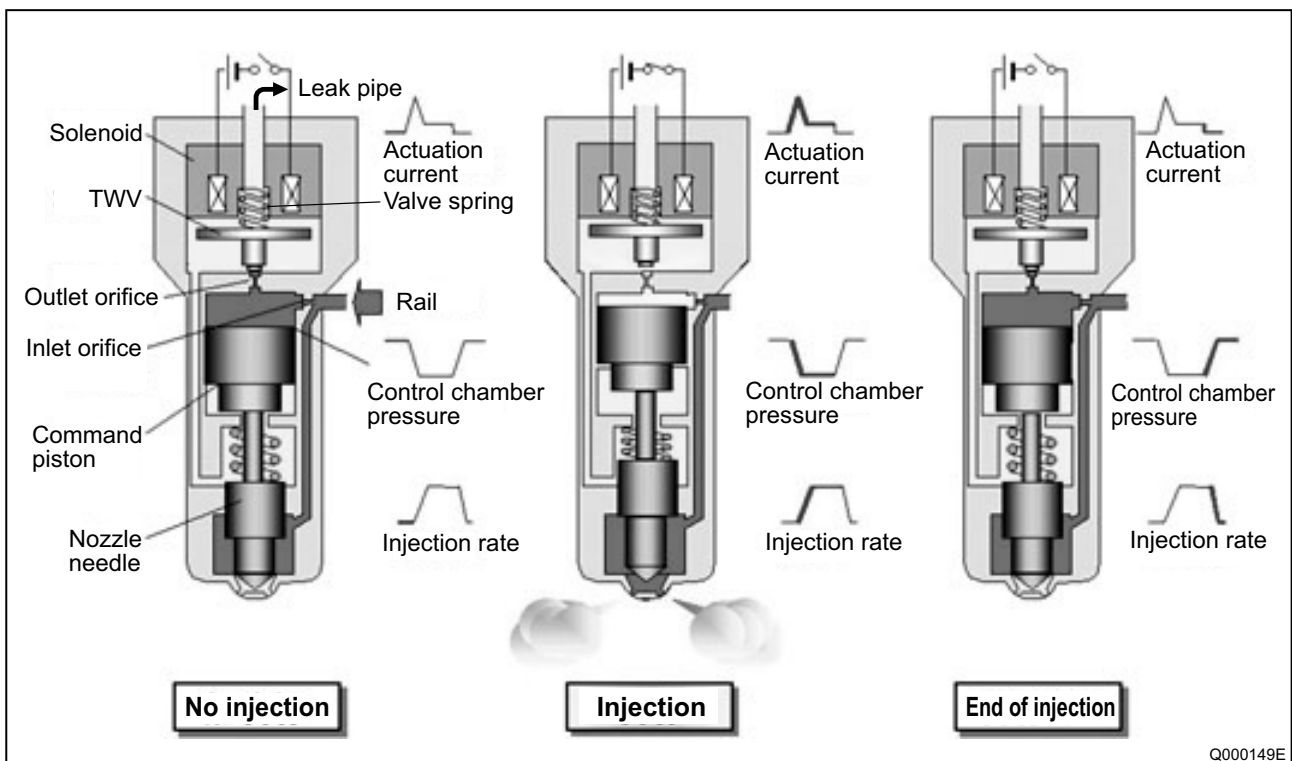

d. QR codes

- Conventionally, adjusting resistors were used for fuel injection quantity correction. However, QR ^{*1} (Quick Response) codes have been adopted to enhance correction precision.
- Using QR codes has resulted in a substantial increase in the number of fuel injection quantity correction points, and thus the injection quantity control precision has improved. The characteristics of the engine cylinders have been further unified, contributing to improvements in combustion efficiency, reductions in exhaust gas emissions and so on.

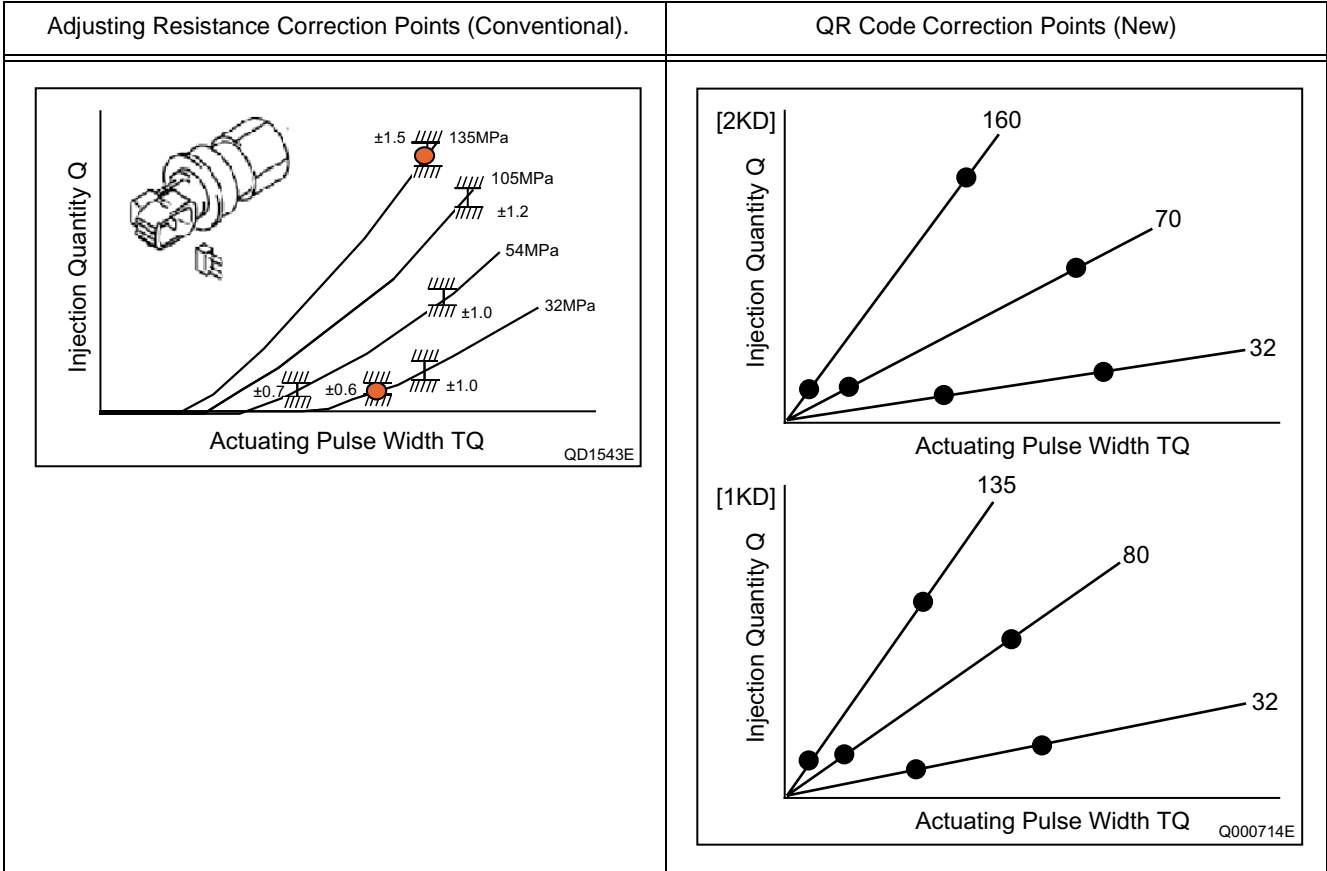

*1: Location of QR codes

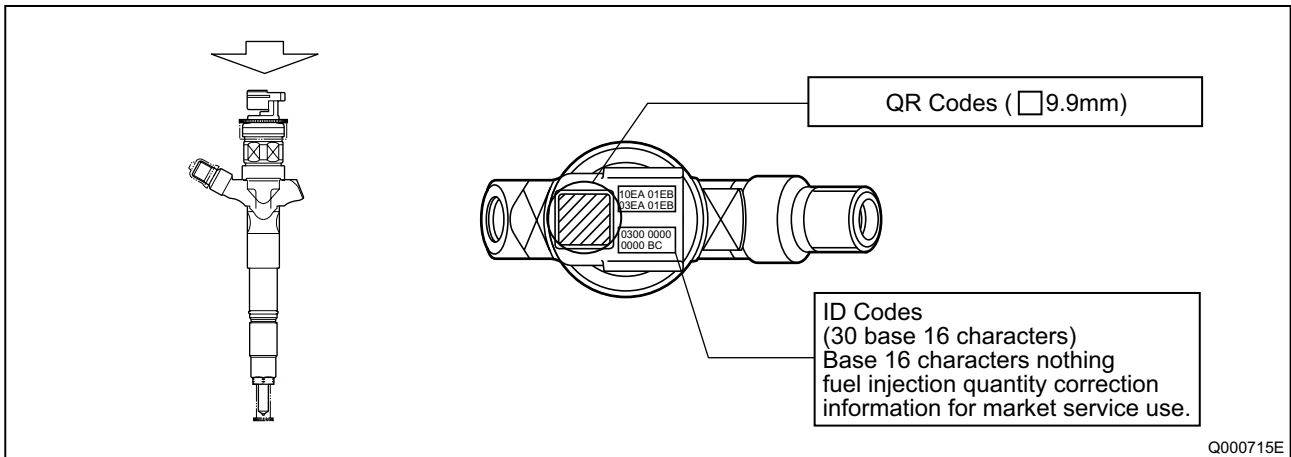

e. Repair Procedure Changes

Differences in comparison with the conventional adjusting correction resistor injectors are as shown below.

< CAUTION >

- When replacing injectors with QR codes, or the engine ECU, it is necessary to record the ID codes (QR codes) in the ECU. (If the ID codes of the installed injector are not registered correctly, engine failure such as rough idling and noise will result.)

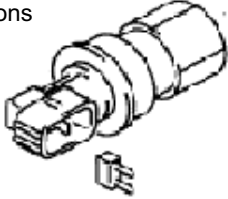
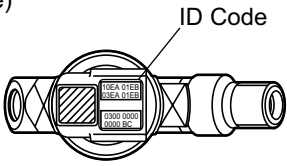
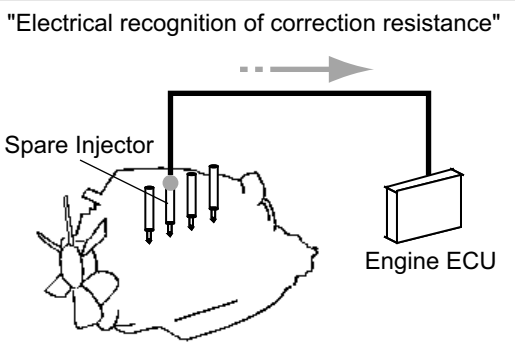
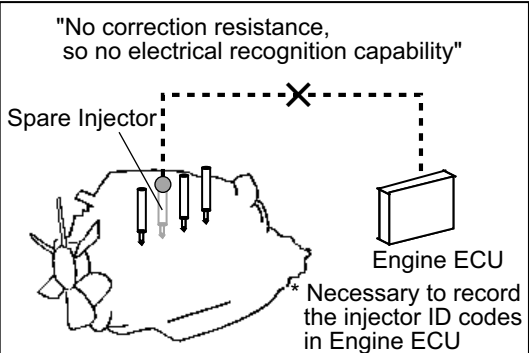
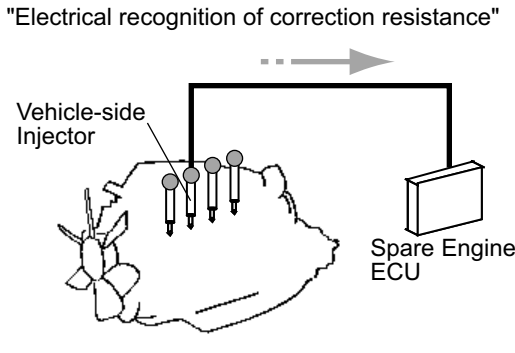
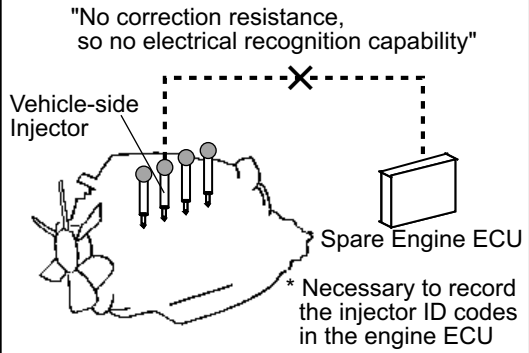
	Conventional (Injector with Correction Resistor)	New (Injector with QR Codes)
	<p>5² (25) combinations</p>  <p>QD1532E</p>	<p>256¹² (almost infinite) combinations</p>  <p>Q000716E</p>
Replacing the Injector	<p>"Electrical recognition of correction resistance"</p>  <p>QD1534E</p>	<p>"No correction resistance, so no electrical recognition capability"</p>  <p>* Necessary to record the injector ID codes in Engine ECU</p> <p>QD1536E</p>
Replacing the Engine ECU	<p>"Electrical recognition of correction resistance"</p>  <p>QD1535E</p>	<p>"No correction resistance, so no electrical recognition capability"</p>  <p>* Necessary to record the injector ID codes in the engine ECU</p> <p>QD1537E</p>

E. Engine ECU (Electronic Control Unit)

a. Outline

This is the command center that controls the fuel injection system and engine operation in general.

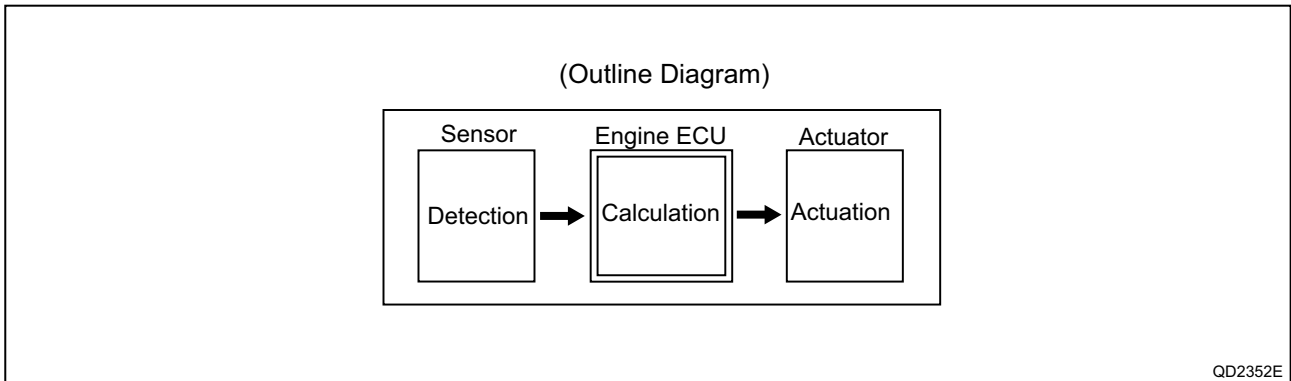

F. EDU (Electronic Driving Unit)

a. Outline

The EDU has been adopted to support the high-speed actuation of the injectors. The high-speed actuation of the injector solenoid valve is made possible through the use of a high-voltage generating device (DC/DC converter).

b. EDU Operation

The high-voltage generating device converts the battery voltage into high voltage. The engine ECU sends signals to terminals B through E of the EDU in accordance with the signals from the sensors. Upon receiving these signals, the EDU outputs signals to the injectors via terminals N through K. At this time, terminal F outputs the I_{jf} injection verification signal to the ECU. The pressure discharge valve is controlled by PRD signals coming to terminal R.

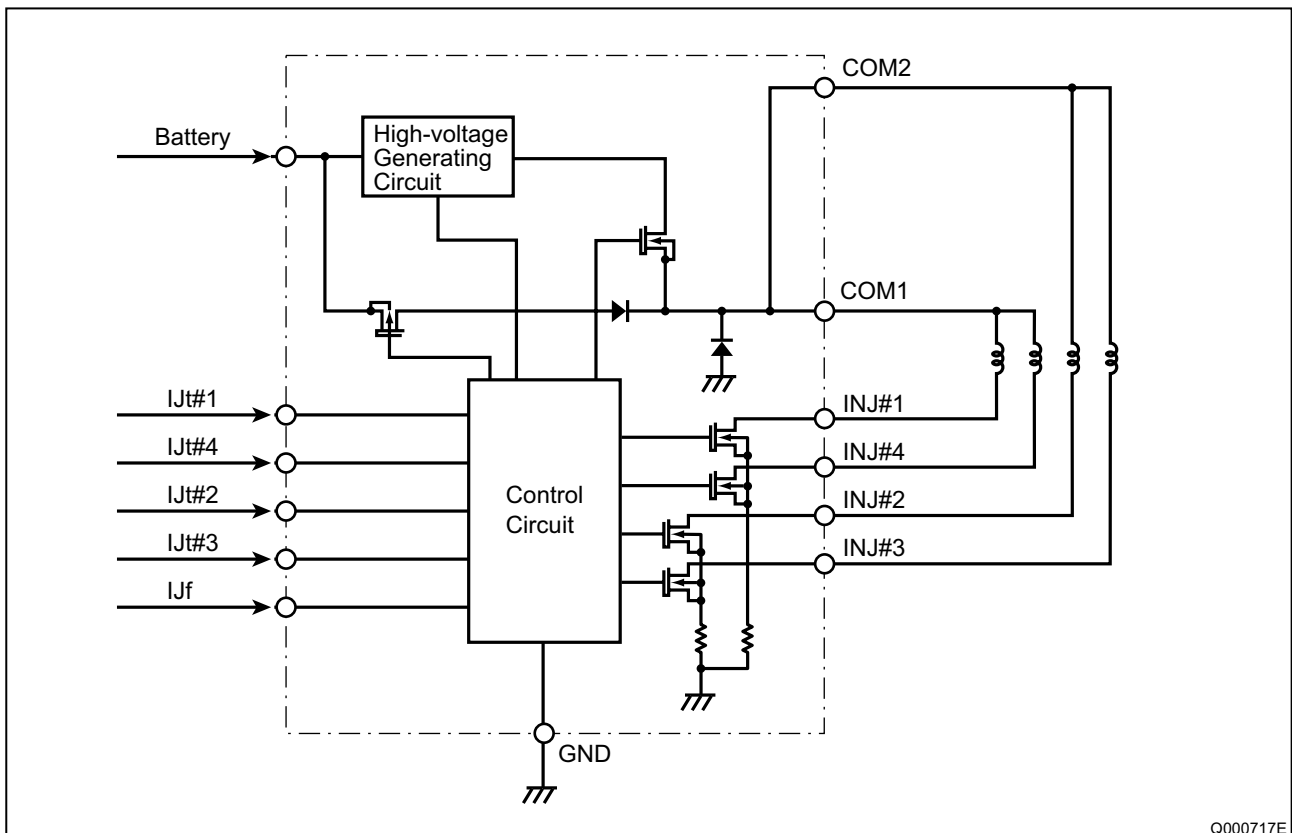

3-2. DESCRIPTION OF CONTROL SYSTEM COMPONENTS

A. Engine Control System Diagram

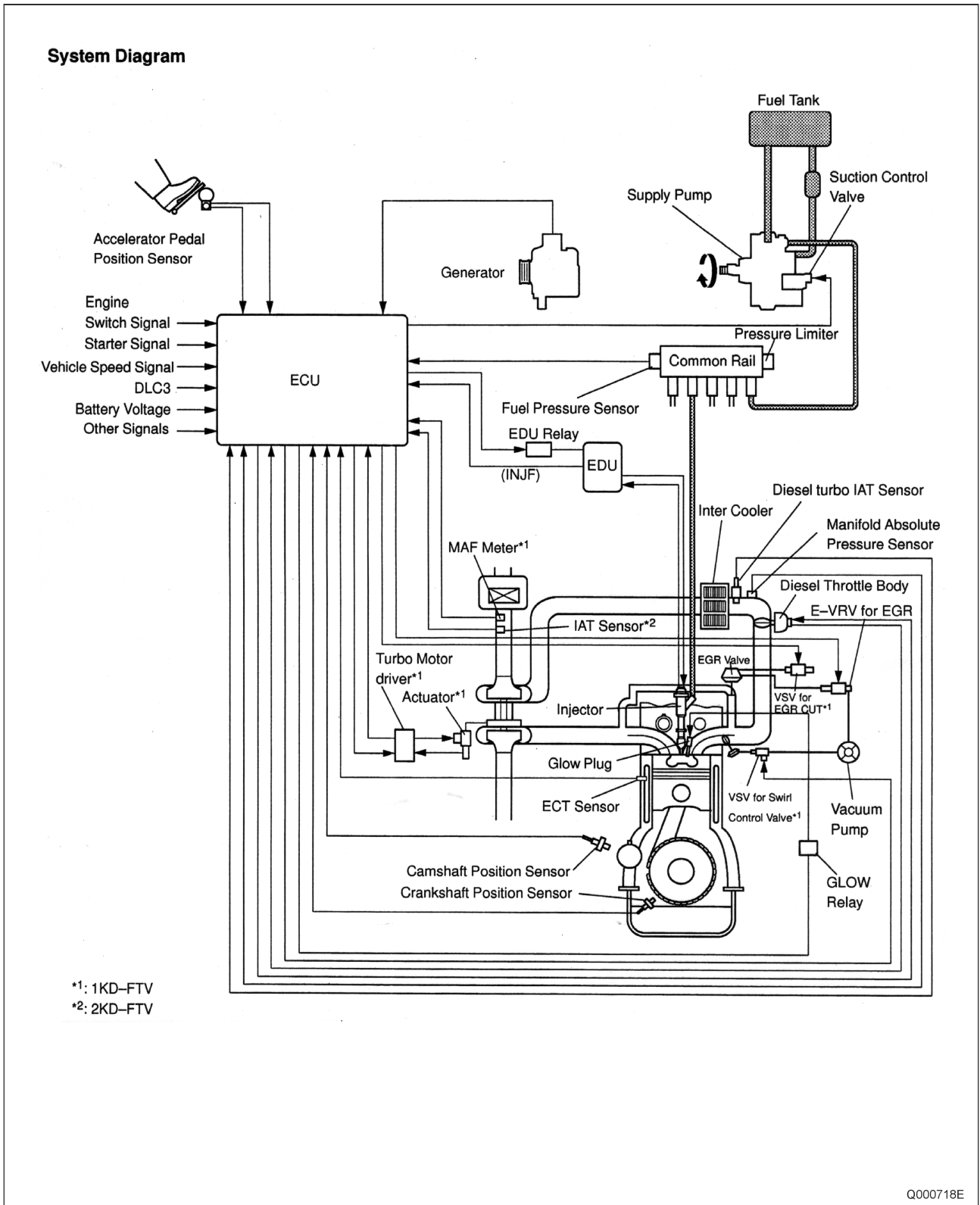

B. Description of Sensors

a. Crankshaft Position Sensor (NE)

An NE pulsar attached to the crankshaft timing gear outputs a signal for detecting the crankshaft angle and engine speed. The pulsar gear contains 34 gears, with 2 gears missing (for 2 pulses), and the sensor outputs 34 pulses for 360°CA.

b. Cylinder Recognition Sensor (G)

A cylinder recognition sensor (G pulsar) is attached to the supply pump timing gear, and outputs a cylinder recognition signal. The sensor outputs 1 pulse for each 2 engine revolutions.

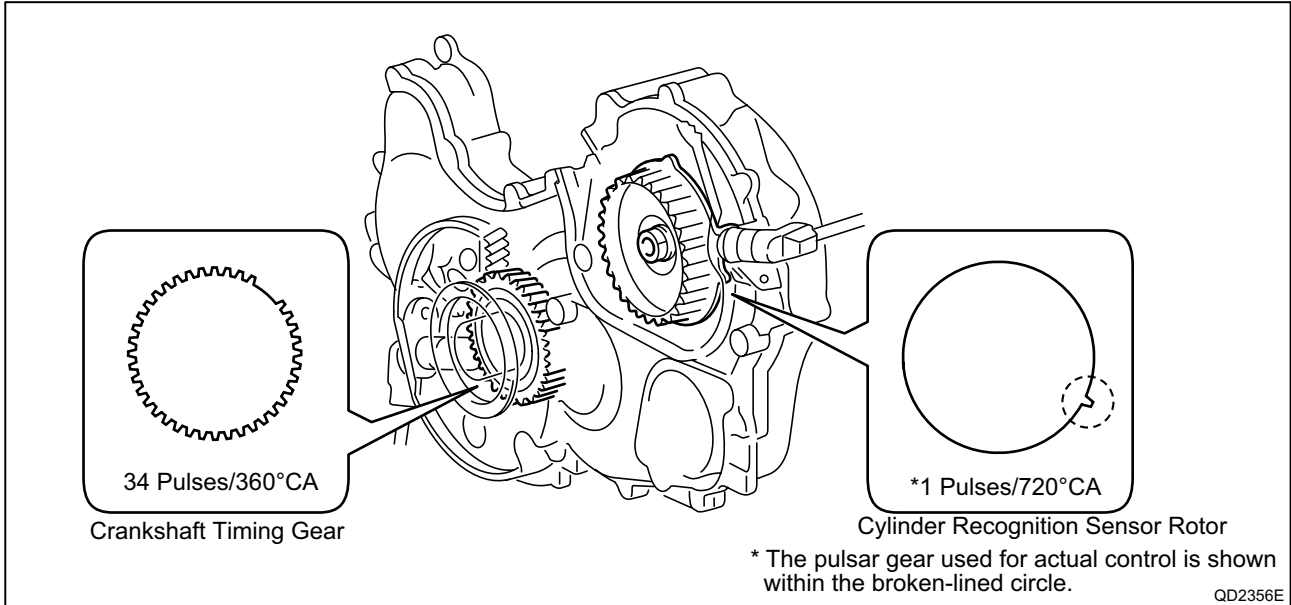

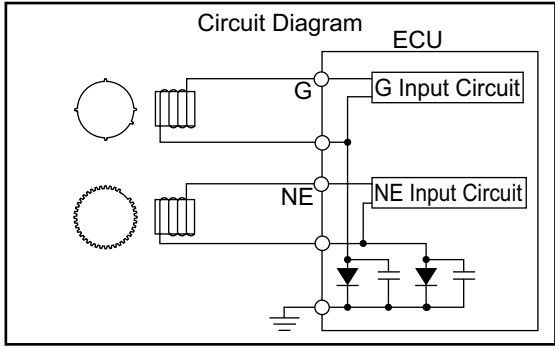
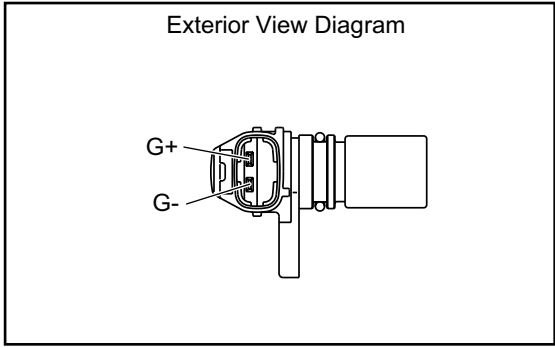

* The engine ECU identifies the No. 1 cylinder when it detects the missing-tooth NE pulse and the cylinder recognition pulse (G Pulse) simultaneously.

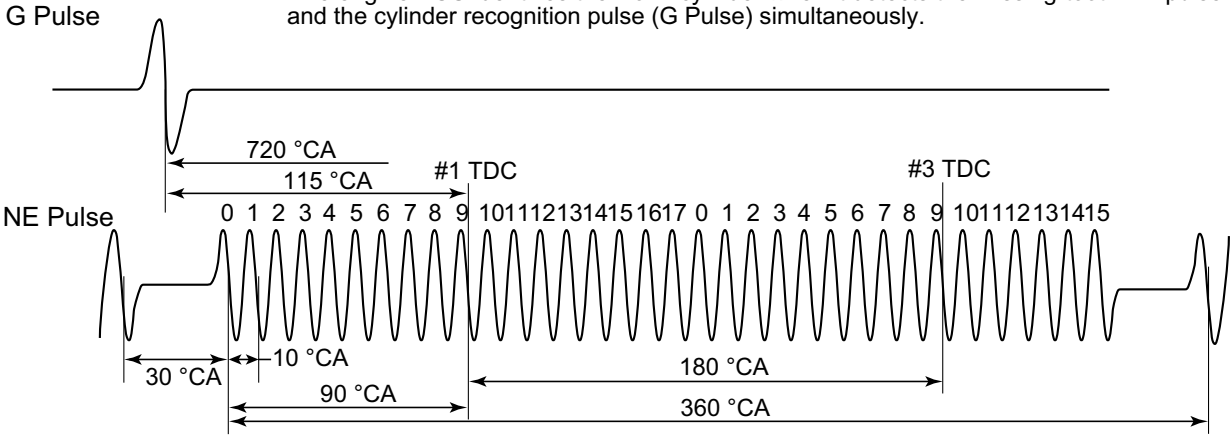

QD2357E

c. Accelerator Position Sensor

The accelerator position sensor is a non-contact point type sensor with a lever that rotates in unison with the accelerator pedal. The voltage (VPA1, VPA2) of the output terminal varies in accordance with the rotational angle of the lever. As a safety measure against problems such as an open circuit, the sensor contains two output voltage systems. (The output voltage has an offset of 0.8V.)

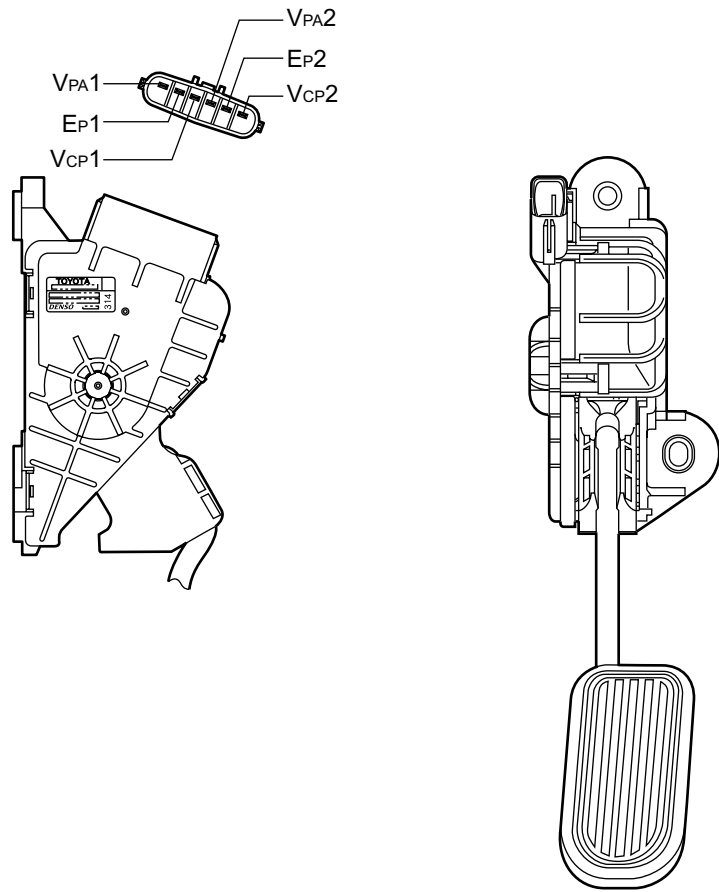

Linear Output Characteristics Graph

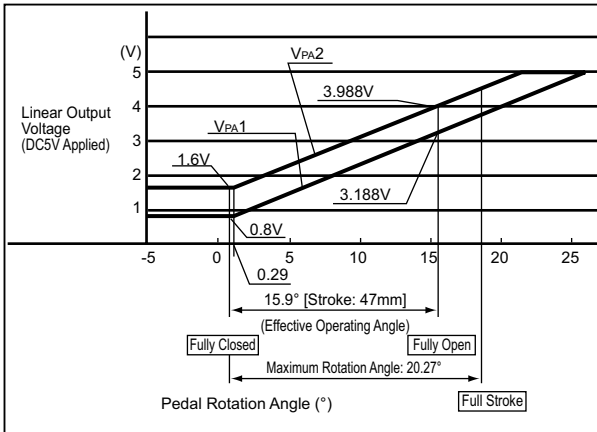

Wiring Diagram

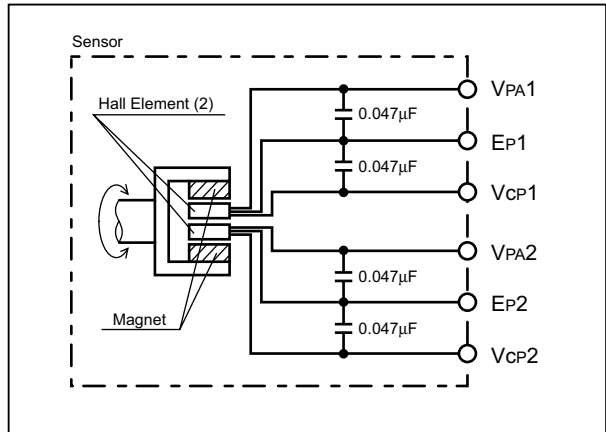

Q000719E

d. Intake Air Pressure Sensor

This is a type of semi-conductor pressure sensor. It utilizes the characteristics of the electrical resistance changes that occur when the pressure applied to a silicon crystal changes. Because a single sensor is used to measure both intake air pressure and atmospheric pressure, a VSV is used to alternate between atmospheric and intake air pressure measurement.

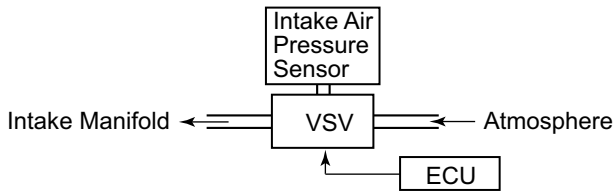
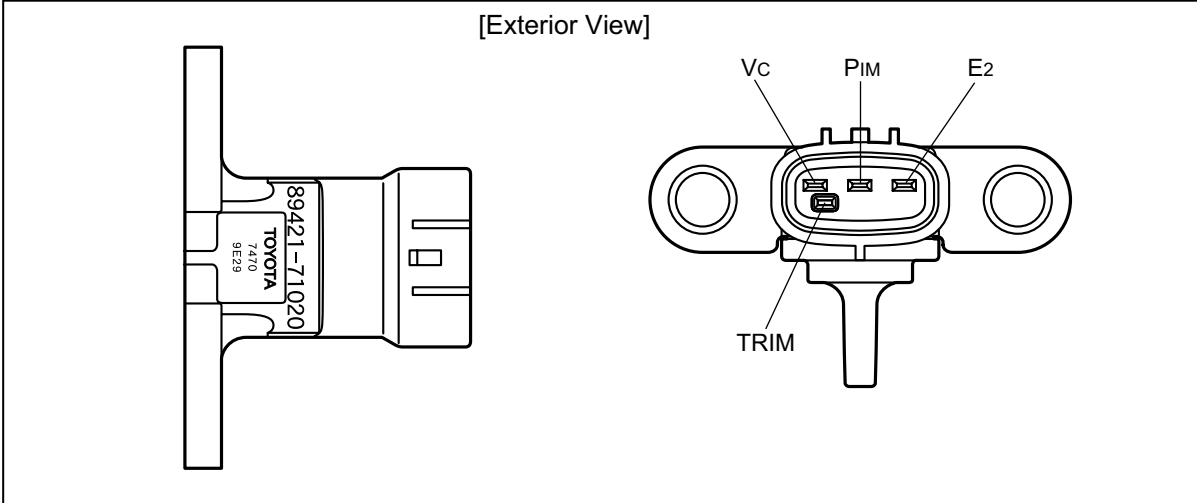

Atmospheric Pressure Measurement Conditions:

The VSV turns ON for 150msec to detect the atmospheric pressure when one of the conditions "(1)" to "(3)" given below is present.

- (1) Engine speed = 0rpm
- (2) Starter is ON
- (3) Idle is stable

Intake Air Pressure Measurement Conditions:

The VSV turns OFF to detect the intake air pressure if the atmospheric pressure measurement conditions are absent.

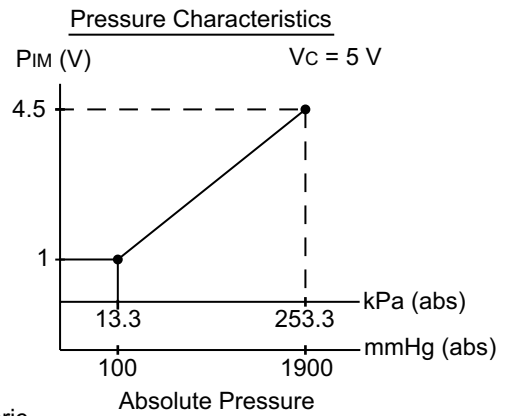

Q000720E

e. Coolant Temperature Sensor (THW)

- The coolant temperature sensor (Pc sensor) is attached to the engine cylinder block and detects the engine coolant temperature.
- The sensor uses a thermistor. The thermistor has a characteristic in which the resistance changes with the temperature, and the change in resistance value is used to detect the coolant temperature changes.
- Its characteristic is that the resistance value decreases as the temperature increases.

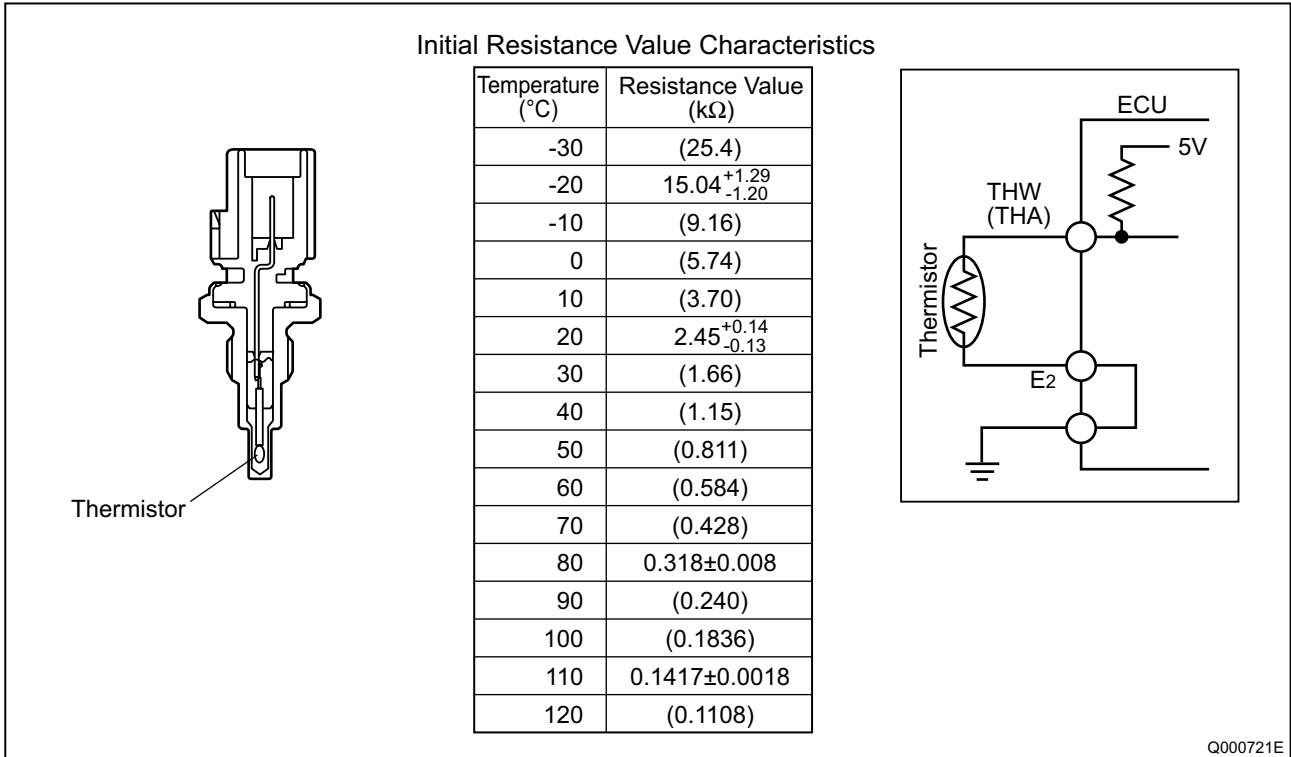

f. Fuel Temperature Sensor (THF)

- The fuel temperature sensor is mounted on the supply pump, and detects the fuel temperature, sending a signal to the engine ECU.
- The detection component utilizes a thermistor.

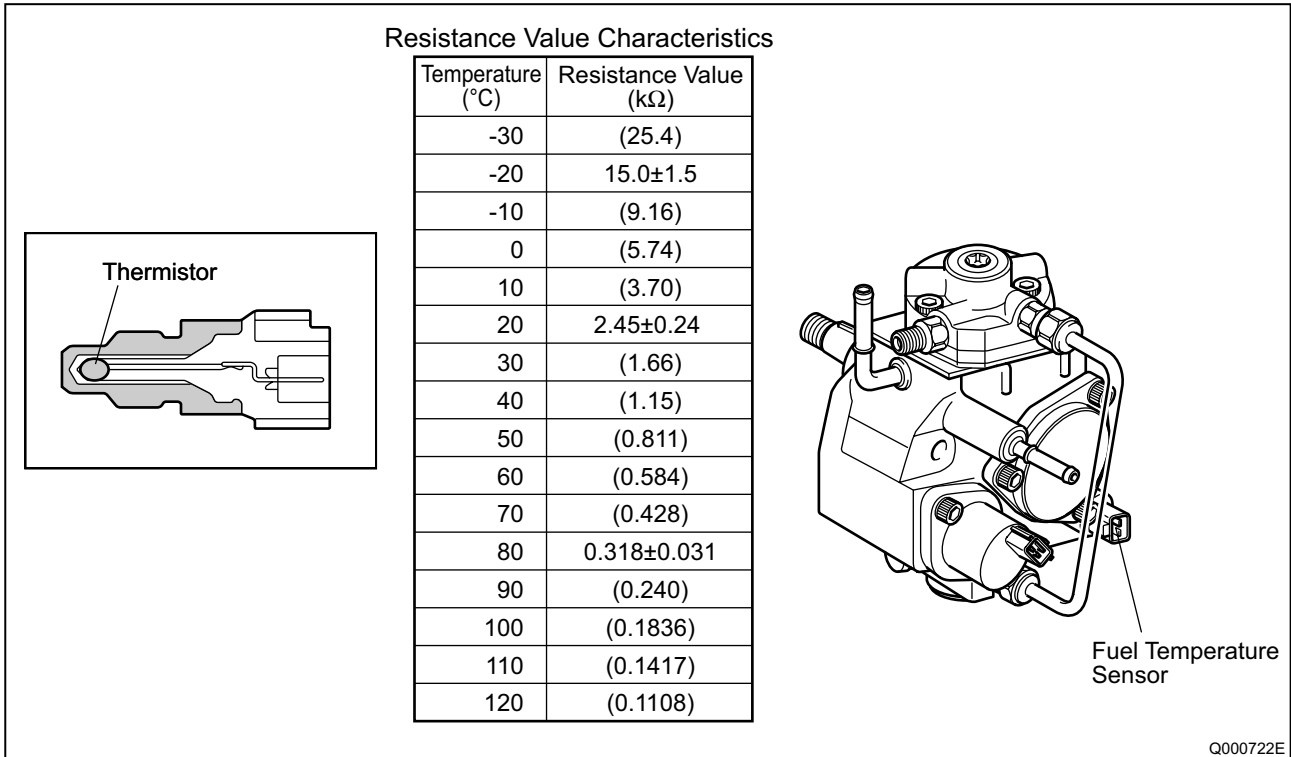

C. Various Types of Controls

a. Outline

This system effects fuel injection quantity and injection timing control more appropriately than the mechanical governor and timer used in the conventional injection pump. The engine ECU performs the necessary calculations in accordance with the sensors installed on the engine and the vehicle. It then controls the timing and duration of time in which current is applied to the injectors, in order to realize both optimal injection and injection timing.

b. Fuel Injection Rate Control Function

Pilot injection control injects a small amount of fuel before the main injection.

c. Fuel Injection Quantity Control Function

The fuel injection quantity control function replaces the conventional governor function. It controls the fuel injection to an optimal injection quantity based on the engine speed and accelerator position signals.

d. Fuel Injection Timing Control Function

The fuel injection timing control function replaces the conventional timer function. It controls the injection to an optimal timing based on the engine speed and the injection quantity.

e. Fuel Injection Pressure Control Function (Rail Pressure Control Function)

The fuel injection pressure control function (rail pressure control function) controls the discharge volume of the pump by measuring the fuel pressure at the rail pressure sensor and feeding it back to the ECU. It effects pressure feedback control so that the discharge volume matches the optimal (command) value set in accordance with the engine speed and the injection quantity.

D. Fuel Injection Quantity Control

a. Outline

This control determines the fuel injection quantity by adding coolant temperature, fuel temperature, intake air temperature, and intake air pressure corrections to the basic injection quantity calculated by the engine ECU, based on the engine operating conditions and driving conditions.

b. Injection Quantity Calculation Method

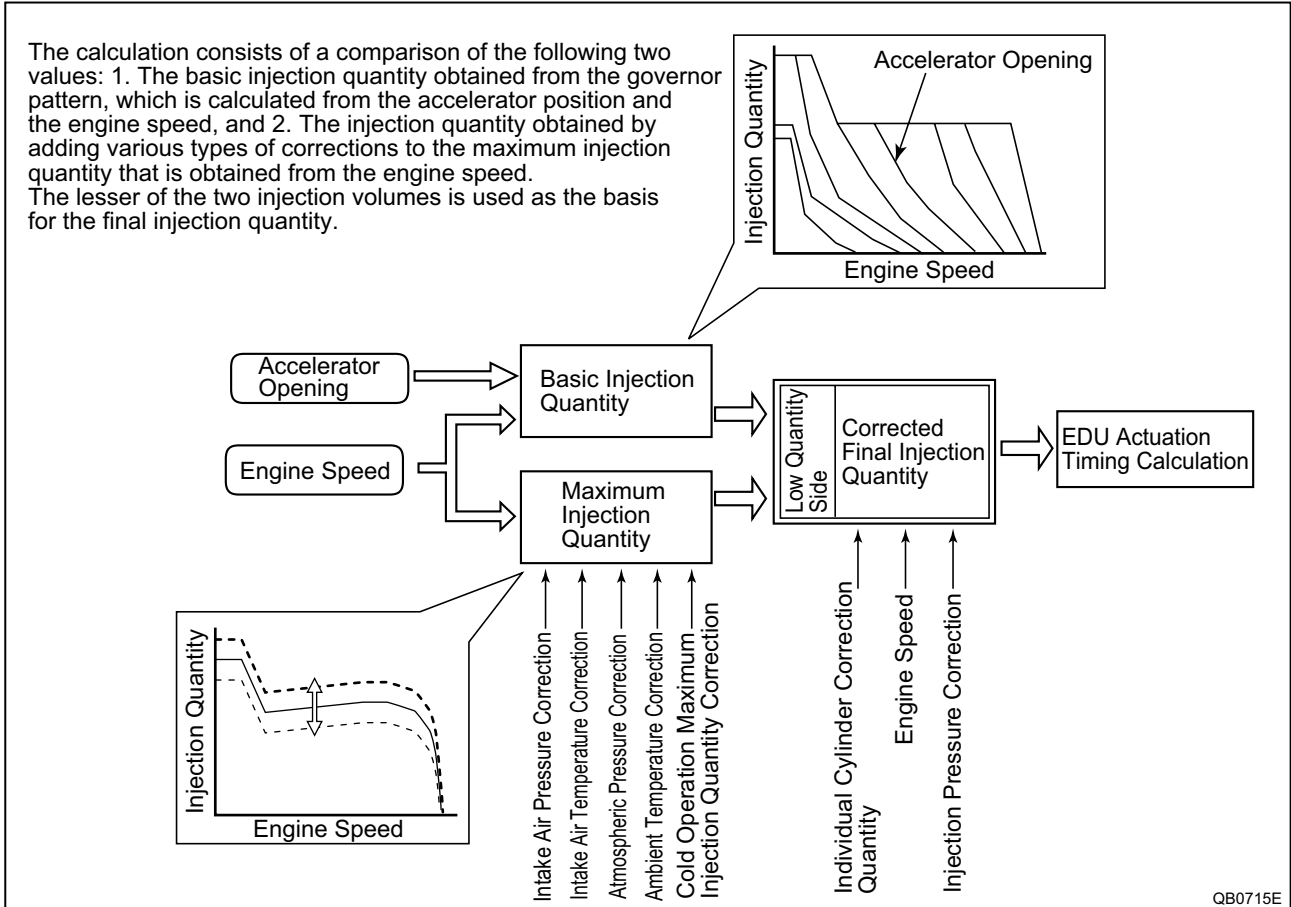

c. Basic Injection Quantity

The basic injection quantity is determined by the engine speed (NE) and the accelerator opening. The injection quantity is increased when the accelerator position signal is increased while the engine speed remains constant.

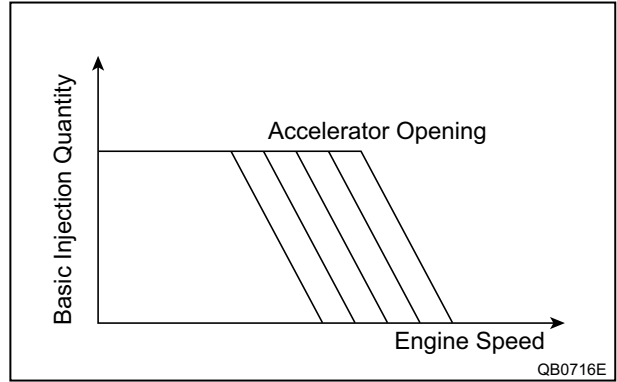

d. Maximum Injection Quantity

The maximum injection quantity is calculated by adding the intake air pressure correction, intake air temperature correction, atmospheric pressure correction, ambient temperature correction, and the cold operation maximum injection quantity correction to the basic maximum injection quantity determined by the engine speed.

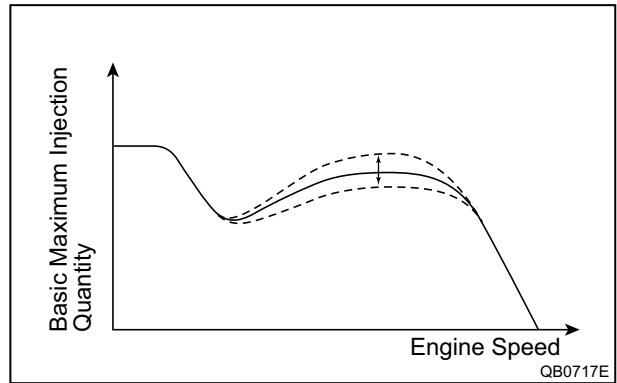

e. Starting Injection Quantity

When the starter switch is turned ON, the injection quantity is calculated in accordance with the starting base injection quantity and the starter ON time. The base injection quantity and the inclination of the quantity increase/decrease change in accordance with the coolant temperature and the engine speed.

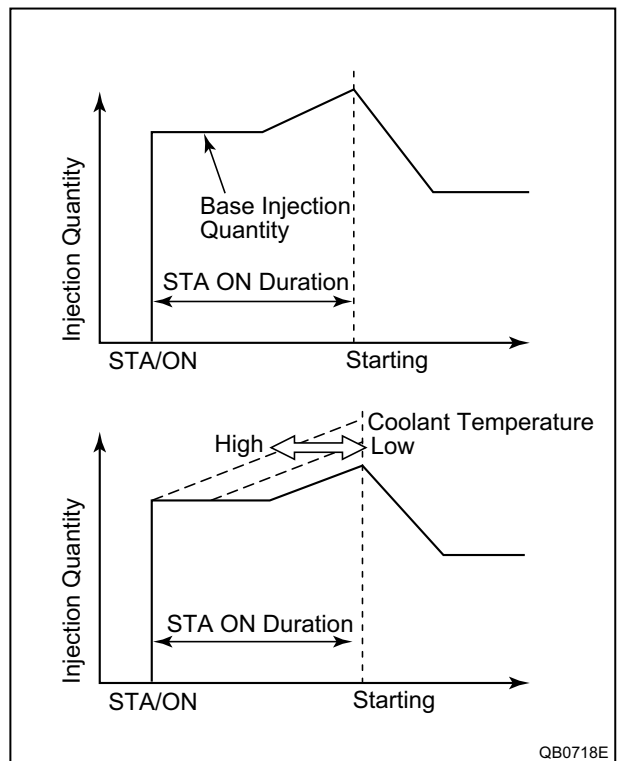

f. Idle Speed Control (ISC) System

This system controls the idle speed by regulating the injection quantity in order to match the actual speed to the target speed calculated by the engine ECU.

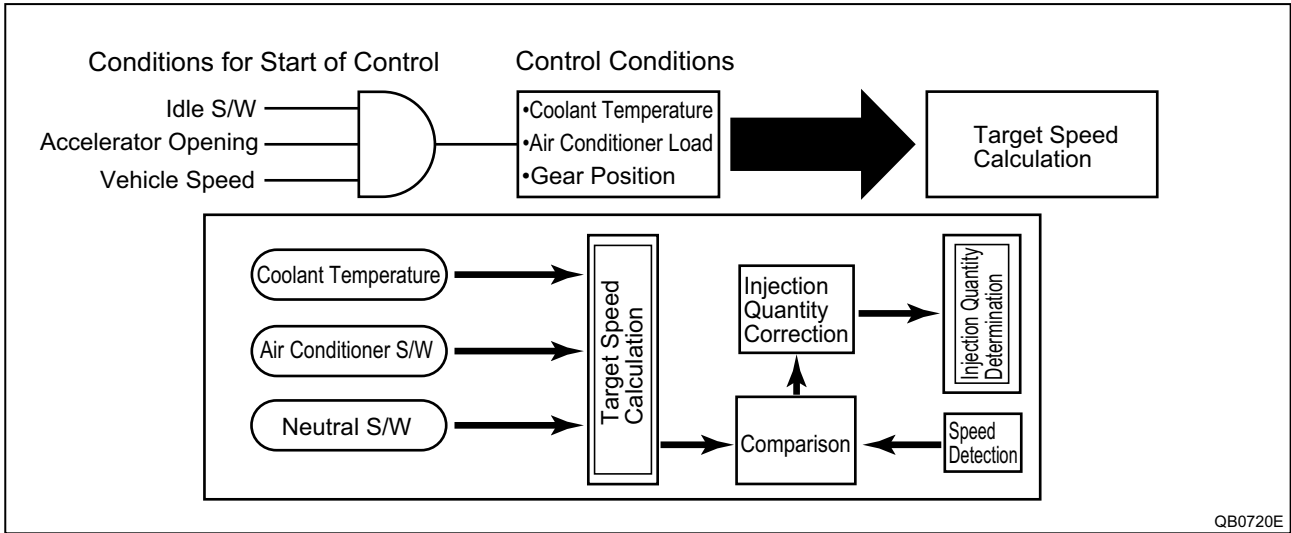

g. Idle Vibration Reduction Control

To reduce engine vibrations during idle, this function compares the angle speeds (times) of the cylinders and regulates the injection quantity for the individual cylinders if there is a large difference, in order to achieve a smooth engine operation.

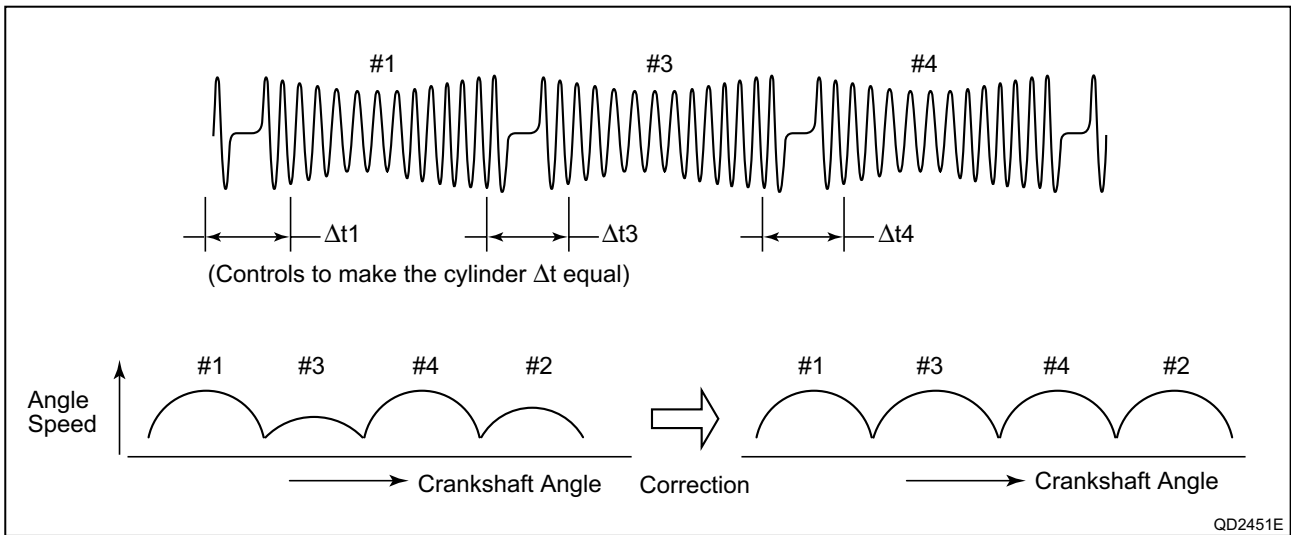

E. Fuel Injection Timing Control

a. Outline

Fuel injection timing is controlled by varying the timing in which current is applied to the injectors.

b. Main and Pilot Injection Timing Control

(1) Main Injection Timing

The engine ECU calculates the basic injection timing based on the engine speed and the final injection quantity, and adds various types of corrections in order to determine the optimal main injection timing.

(2) Pilot Injection Timing (Pilot Interval)

Pilot injection timing is controlled by adding a pilot interval to the main injection timing. The pilot interval is calculated based on the final injection quantity, engine speed, coolant temperature, ambient temperature, and atmospheric pressure (map correction). The pilot interval at the time the engine is started is calculated from the coolant temperature and engine speed.

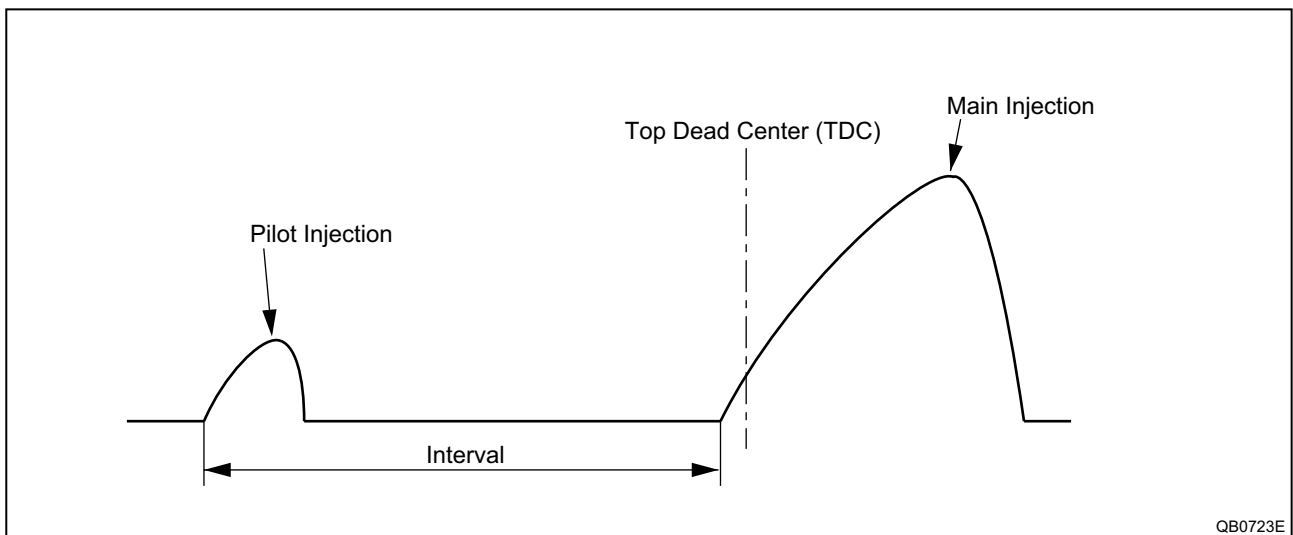

c. Injection Timing Calculation Method

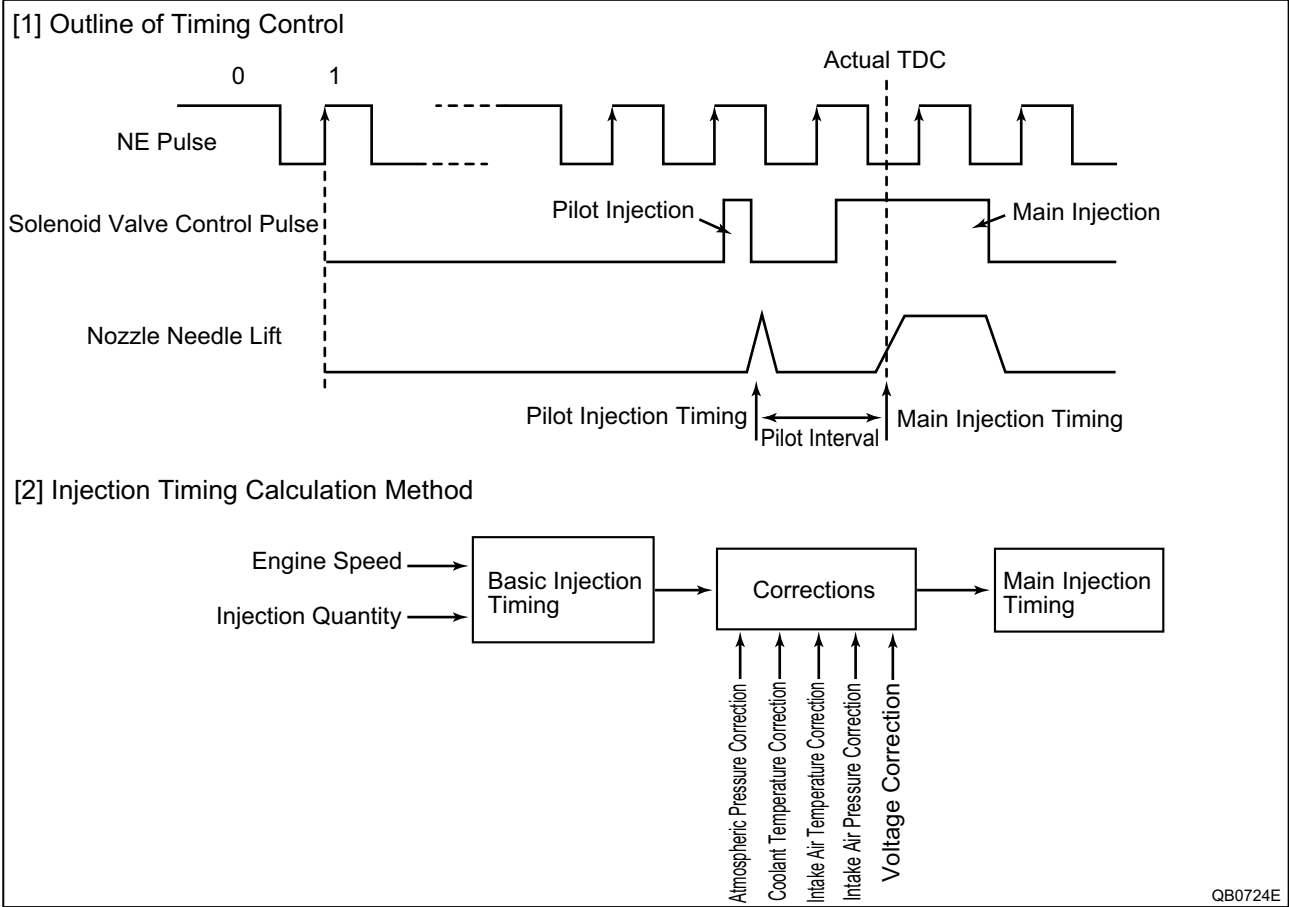

F. Fuel Injection Rate Control

a. Outline

While the injection rate increases with the adoption of high-pressure fuel injection, the ignition lag, which is the delay from the time fuel is injected to the beginning of combustion, cannot be shortened to less than a certain value. As a result, the quantity of fuel that is injected until main ignition occurs increases, resulting in an explosive combustion at the time of main ignition. This increases both NO_x and noise. For this reason, pilot injection is provided to minimize the initial ignition rate, prevent the explosive first-stage combustion, and reduce noise and NO_x.

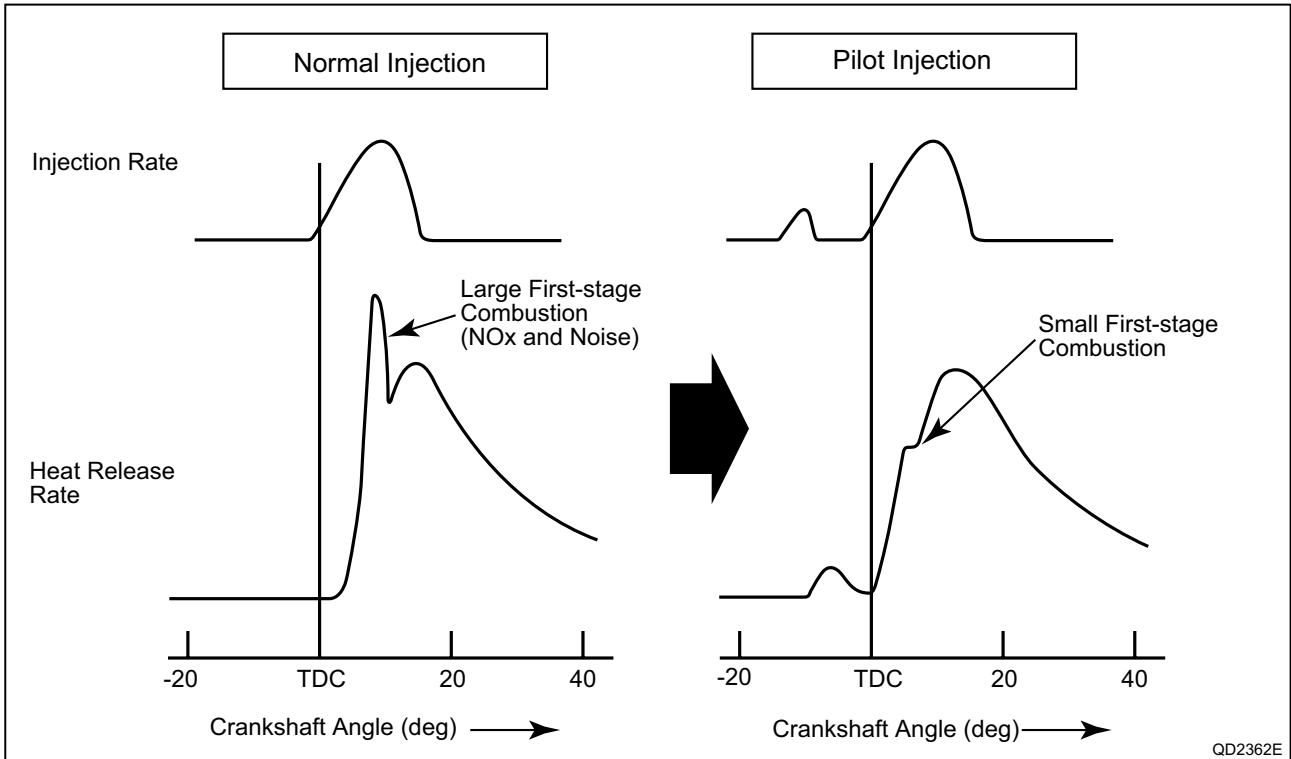

G. Fuel Injection Pressure Control

a. Fuel Injection Pressure

The engine ECU determines the fuel injection pressure based on the final injection quantity and the engine speed. The fuel injection pressure at the time the engine is started is calculated from the coolant temperature and engine speed.

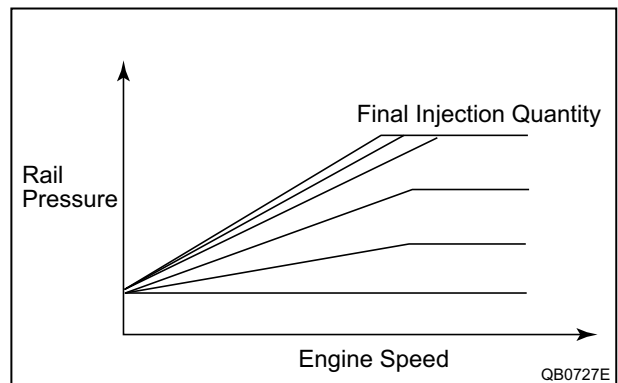

3-3. EGR CONTROL SYSTEM

A. Outline and Operation

a. Outline

By sensing the engine driving conditions and actual amount of EGR valve opening, the engine ECU electrically operates the E-VRV, which controls the magnitude of vacuum introduced into diaphragm of EGR valve and throttle opening position with stepping motor and the amount of recirculating exhaust gas is regulated.

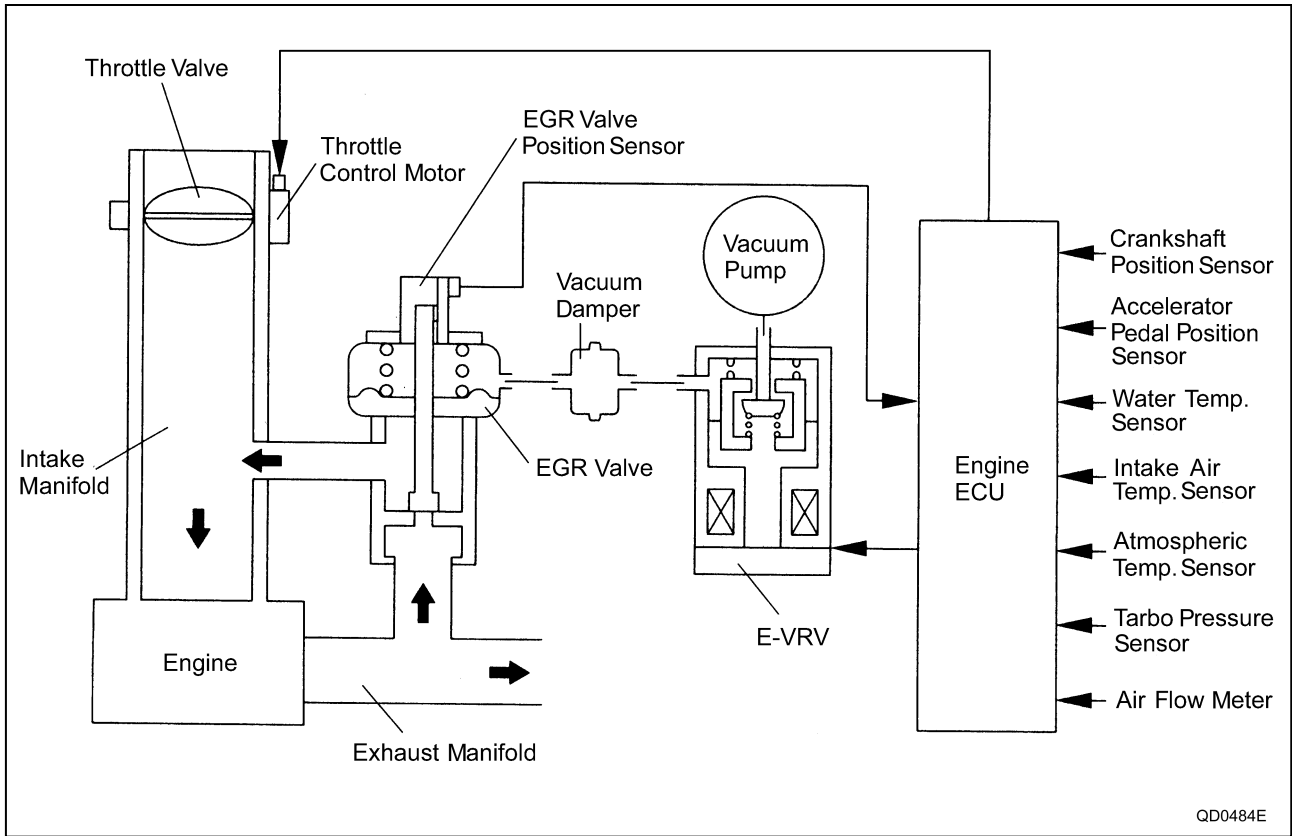

b. Operation Principle of E-VRV

(1) To increase the EGR volume:

In the stable condition shown in the center diagram, when the current* applied to the coil increases, the attraction force FM of the coil increases. When this force becomes greater than the vacuum force FV that acts on the diaphragm, the moving core moves downward. Because the port that connects the vacuum pump to the upper diaphragm chamber opens in conjunction with the movement of the moving core, the output vacuum becomes higher and the EGR volume increases. Meanwhile, because "increased output vacuum equals increased FV", the moving core moves upward with the increase in FV. When FM and FV are equal, the port closes and the forces stabilize. Because the vacuum circuit of the EGR is a closed loop, it maintains the vacuum in a stabilized state, providing there are no changes in the amperage.

*1: The engine ECU outputs sawtooth wave signals with a constant frequency. The value of the current is the effective (average) value of these signals.

(2) To decrease the EGR volume:

A decrease in the current that is applied to the coil, causes the FV to become greater than the FM. As a result, the diaphragm moves upward. The moving core also moves upward in conjunction with the movement of the diaphragm, causing the valve that seals the upper and lower diaphragm chambers to open. This causes the atmosphere in the lower chamber to flow into the upper chamber, thus lowering the output vacuum and reducing the EGR volume. Because "decreased output vacuum equals decreased FV", the moving core moves downward with the decrease in FV. When FM and FV are equal, the port closes and the forces stabilize.

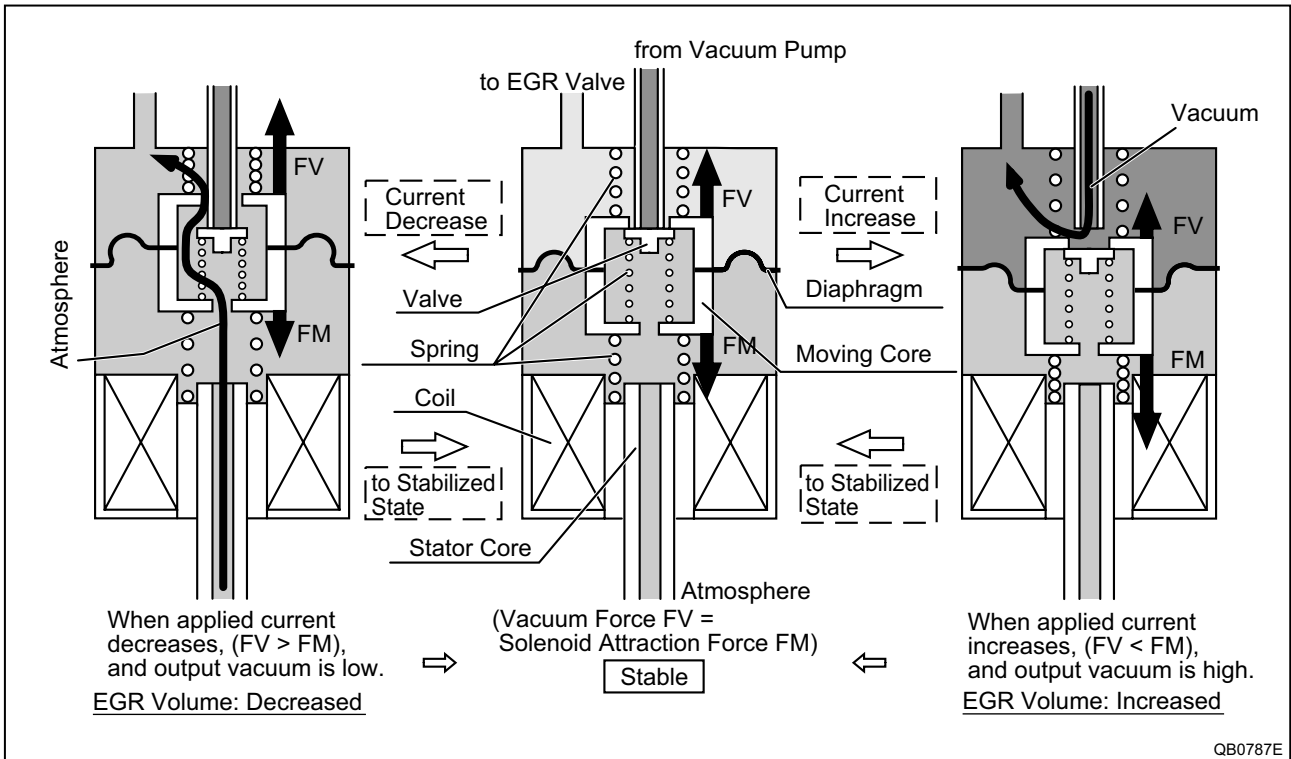

QB0787E

3-4. DIESEL THROTTLE (ELECTRONICALLY CONTROLLED INTAKE AIR THROTTLE MECHANISM)

A. Outline and Operation

a. Outline

An electronically controlled intake air throttle valve mechanism has been adopted. Located in the intake manifold upstream of the EGR valve, this mechanism optimally controls the intake air throttle valve angle to control the flow of the EGR gas, and reduce noise and exhaust gas emissions. The diesel throttle Assy is made by another manufacturer.

b. Construction and Operation

The signals from the engine ECU actuate the stepping motor, which regulates the opening of the intake air throttle valve.

A) EGR Control

To further increase the EGR volume when the EGR valve is fully open, the intake air throttle valve opening is reduced and the vacuum in the intake manifold is increased by restricting the flow of intake air.

B) Noise and Exhaust Gas Reduction

- When the engine is being started, the intake air throttle valve is opened fully to reduce the emission of white and black smoke.
- When the engine is being stopped, the intake air throttle valve is closed fully to reduce vibrations and noise.
- During normal driving, the opening is regulated in accordance with the operating conditions of the engine, the coolant temperature, and the atmospheric pressure.

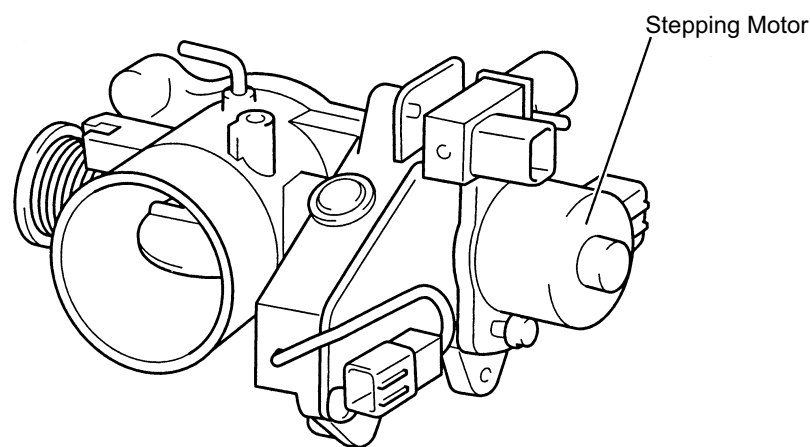

Electronically Controlled Restrictor (Diesel Throttle)

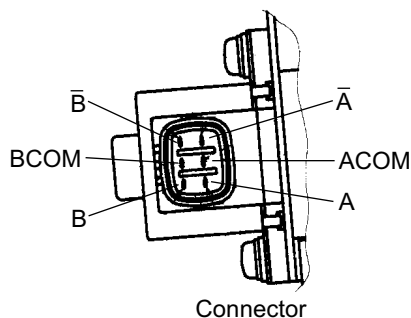

Connector

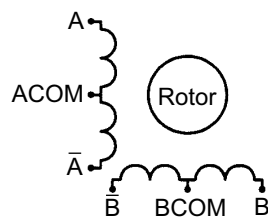

Equivalent Circuit

QD2363E

3-5. FUEL FILTER WARNING

- A fuel filter warning light has been added to notify the driver when fuel filter clogging is detected. Although it does not form part of the common rail system, it is included for reference as a related fuel system function.

A. Role of the Fuel Filter in the Common Rail System

The role of the fuel filter is to remove foreign material and moisture from the fuel. In particular, the common rail system requires constantly high fuel quality as demonstrated in the following point, and the filter thus plays an extremely important role.

- Fuel lubricates the entire supply pump.
- The extremely high discharge pressure (maximum 160MPa) of the supply pump means that foreign material adhesion may result in sliding part and valve malfunction.

B. Installation Position

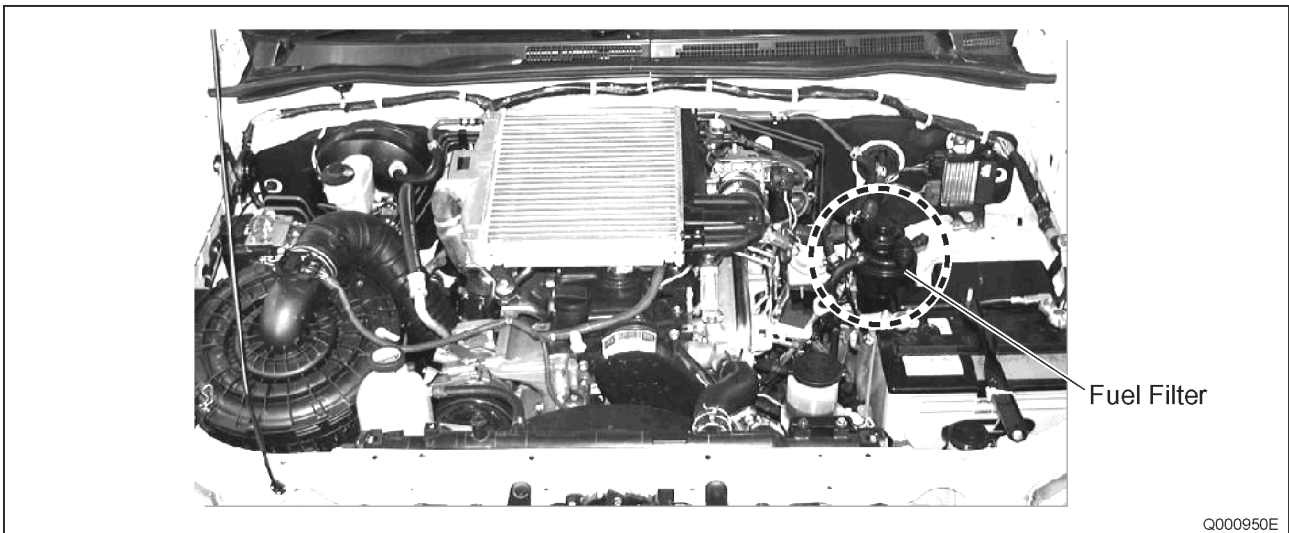

C. System Operation

a. General Description

When the fuel filter clogs, the detection switch installed on the fuel filter operates to turn ON the fuel filter warning light on the instrument cluster.

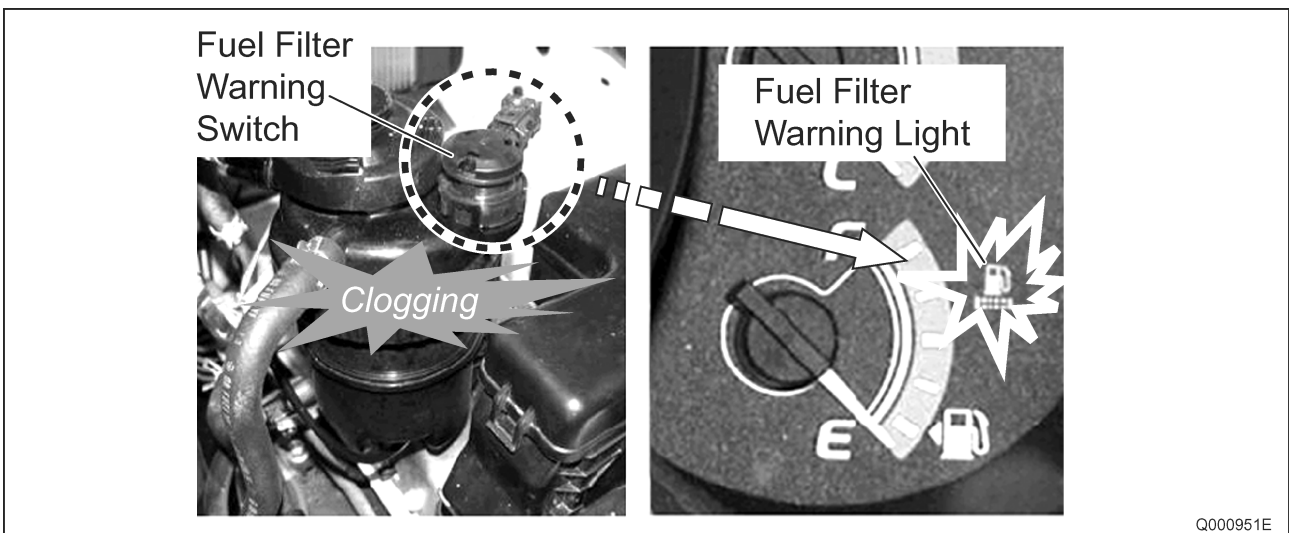

b. Complete Circuit

As shown below, signals from the two sensors installed on the filter (fuel filter warning switch and fuel sedimenter level warning switch) are input to the meter ECU, and the meter ECU actuates the fuel filter warning light.

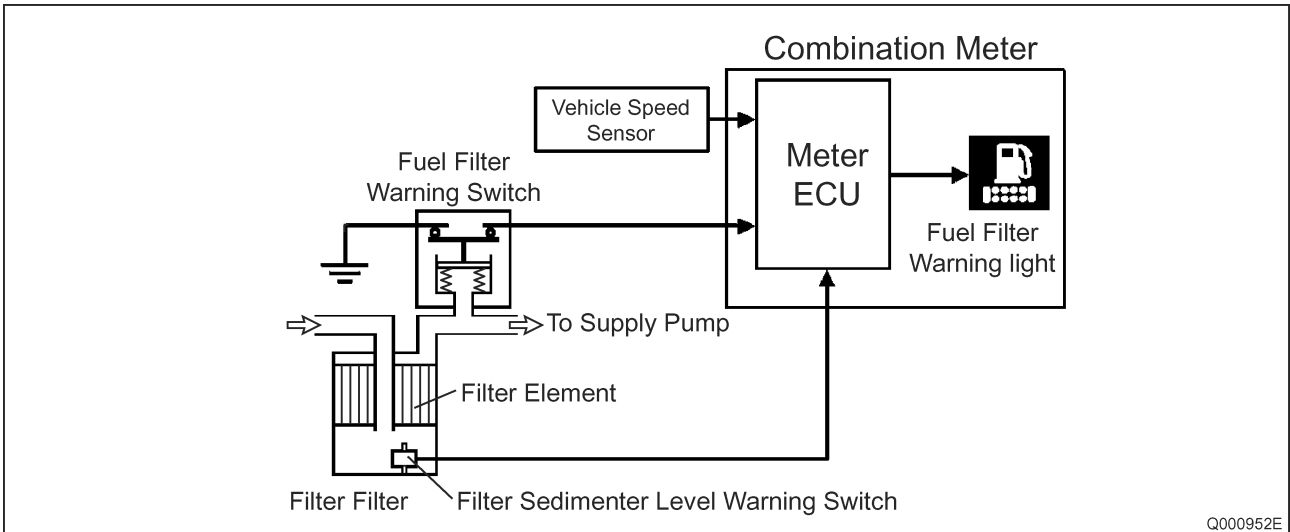

c. Fuel Filter Clogging Warning Operation

- Normal operation (refer to the left side of the diagram below): The fuel filter warning switch contact is closed, and an ON signal is sent to the meter ECU.
- Abnormal operation (refer to the right side of the diagram below): The fuel filter warning switch contact is open, and an OFF signal is sent to the meter ECU.

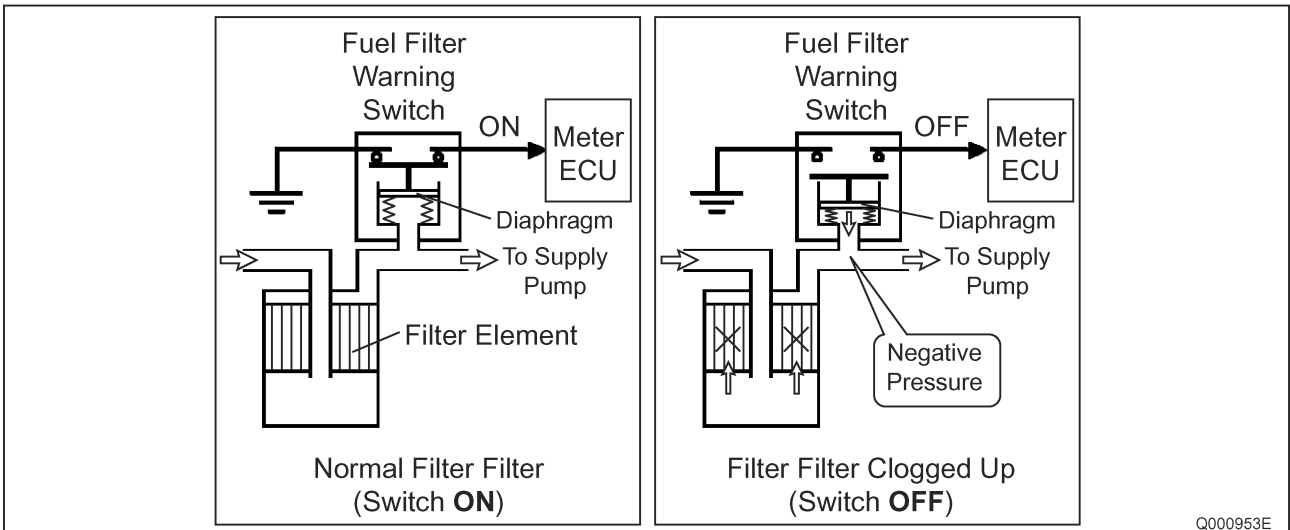

d. Fuel Filter Warning Light Operation

The light blinks in accordance with the sedimenter level warning switch, and turns ON in accordance with the fuel filter warning switch signal.

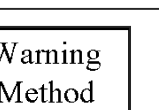
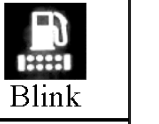
Warning	Warning Method
Sedimenter Warning	 Blink
Fuel Filter Warning	 ON

Q000954E

D. Fuel Filter Replacement (Reference)

- Replace the filter element when the filter is clogged. The shape of the filter element is shown in the diagram on the right.

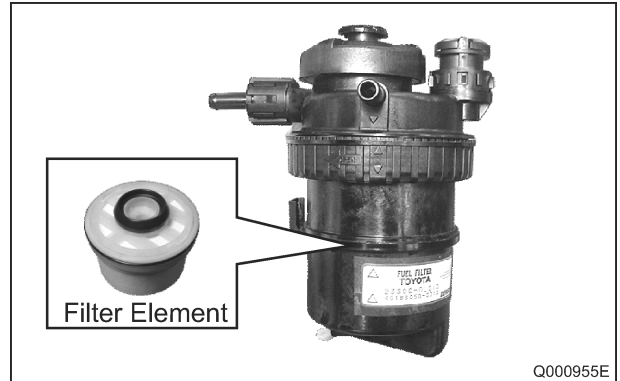

- Loosen the case as shown in the diagram on the right, and replace the filter element. Filter elements are supplied via the TOYOTA route.



4 DIAGNOSIS SYSTEM

4-1. DESCRIPTION

- When troubleshooting Multiplex OBD (M-OBD) vehicles, the vehicle must be connected to the DST-2. Various data output from the vehicle's Engine Control Unit (ECU) can then be read.
- The vehicle's on-board computer illuminates the Malfunction Indicator Lamp (MIL) on the instrument panel when the computer detects a malfunction in the computer itself or in drive system components. In addition, the applicable Diagnostic Trouble Codes (DTCs) are recorded in the ECU memory.
- If the malfunction does not reoccur, the MIL turns ON until the ignition switch is turned OFF, and then the MIL turns OFF when the ignition switch is turned ON but the DTCs remain recorded in the ECU memory.

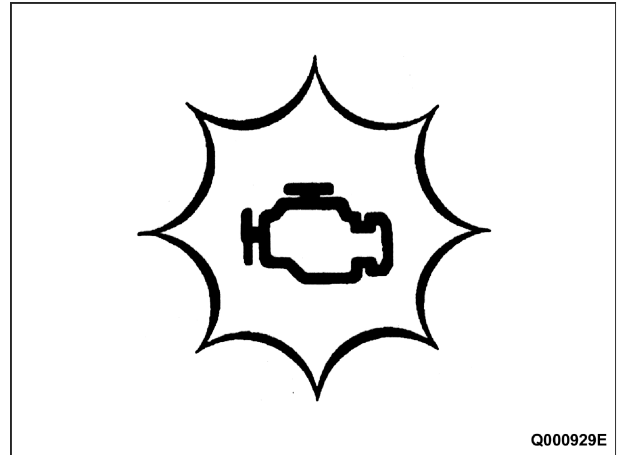

- To check the DTCs, connect the DST-2 to the DLC3 (Data Link Connector 3) on the vehicle or connect terminals TC and CG on the DLC3 (DTCs will be displayed in the combination meter).

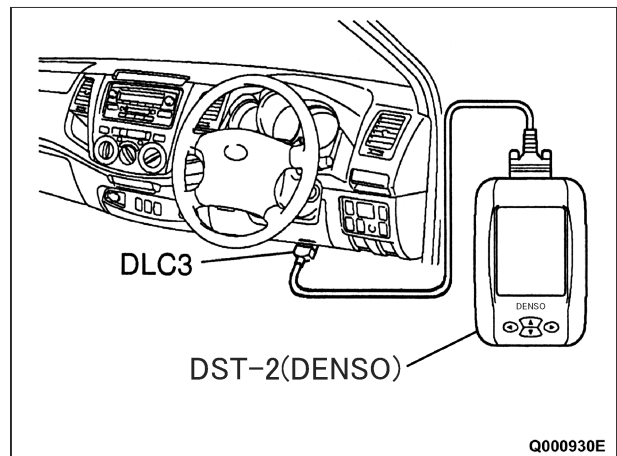

A. Normal Mode and Check Mode

- a. The diagnosis system operates in "normal mode" during normal vehicle use. In normal mode, 2 trip detection logic is used to ensure accurate detection of malfunctions. A "check mode" is also available to technicians as an option. In check mode, 1 trip detection logic is used for simulating malfunction symptoms and increasing the system's ability to detect malfunctions, including intermittent malfunctions.

B. 2 Trip Detection Logic

- a. When a malfunction is first detected, the malfunction is temporarily stored in the ECU memory (1st trip). If the same malfunction is detected during the next subsequent drive cycle, the MIL is illuminated (2nd trip).

C. Freeze Frame Data

- a. The freeze frame data records the engine conditions (fuel system, calculated engine load, engine coolant temperature, fuel trim, engine speed, vehicle speed, etc) when a malfunction is detected. When troubleshooting, the freeze frame data can help determine if the vehicle was running stopped, if the engine was warmed up or not, if the air-fuel ratio was lean or rich, and other data, from the time the malfunction occurred.

D. DLC3

- a. The vehicle's ECU uses the ISO 14230 (M-OBD) communication protocol. The terminal arrangement of the DLC3 complies with ISO 15031-03 and matches the ISO 14230 format.

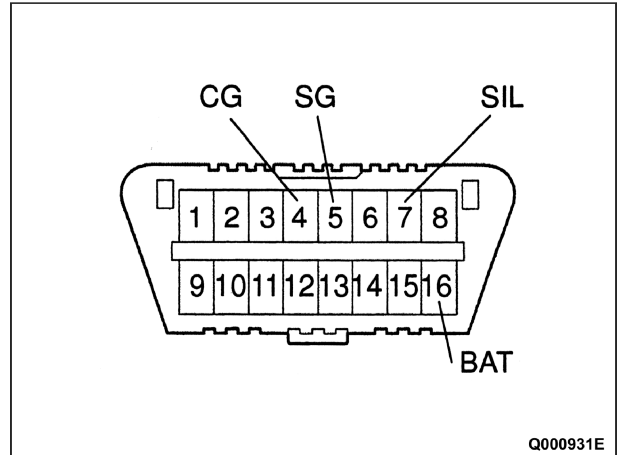

Q000931E

Symbols (Terminal No.)	Terminal Description	Condition	Specified Condition
SIL (7) - SG (5)	Bus "+" line	During transmission	Pulse generation
CG (4) - Body ground	Chassis ground	Always	Below 1Ω
SG (5) - Body ground	Signal ground	Always	Below 1Ω
BAT (16) - Body ground	Battery positive	Always	9 to 14 V

< NOTE >

- Connect the cable of the DST-2 to the DLC3, turn the ignition switch ON and attempt to use the DST-2. If the display informs that a communication error has occurred, there is a problem either with the vehicle or with the tester.
- If communication is normal when the tester is connected to another vehicle, inspect the DLC3 on the original vehicle.
- If communication is still impossible when the tester is connected to another vehicle, the problem is probably in the tester itself. Consult the Service Department listed in the tester's instruction manual.

E. Inspect Battery Voltage

Battery voltage	11 to 14 V
-----------------	------------

- a. If the voltage is below 11 V, recharge the battery before proceeding.

F. Check MIL

- a. The MIL illuminates when the ignition switch is turned ON and the engine is not running.

< NOTE >

- If the MIL is not illuminated, check the MIL circuit.
- b. When the engine is started, the MIL should turn OFF. If the lamp remains ON, the diagnosis system has detected a malfunction or abnormality in the system.

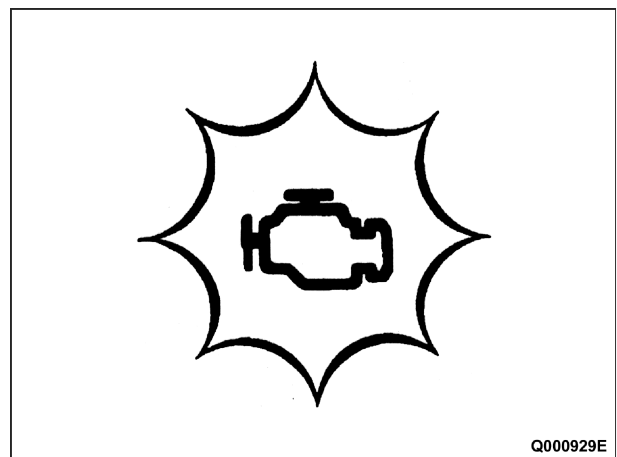

Q000929E

4-2. DTC CHECK/CLEAR

< CAUTION >

- DST-2 only: When the diagnosis system is changed from normal mode to check mode, or vice versa, all the DTCs and freeze frame data recorded in normal mode are erased. Before changing modes, always check and make a note of any DTCs and freeze frame data.

A. Check DTC (using the DST-2)

- Connect the DST-2 to the DLC3.
- Turn the ignition switch ON and turn the DST-2 ON.

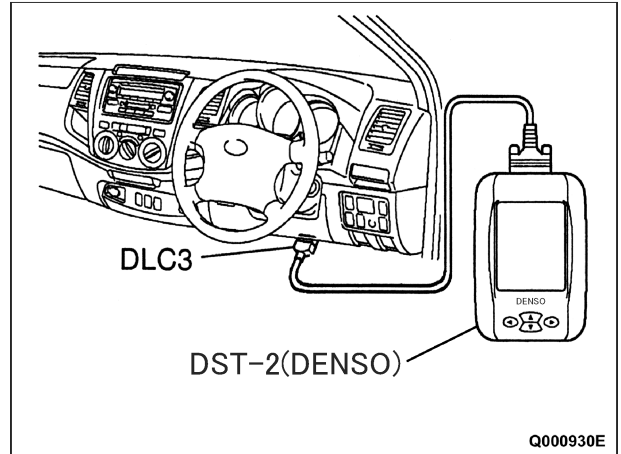

- Enter the following menus: Powertrain/Engine and ECT/ DTC.
- Check and make a note of DTCs and freeze frame data.
- See page 48 to confirm the details of the DTCs.

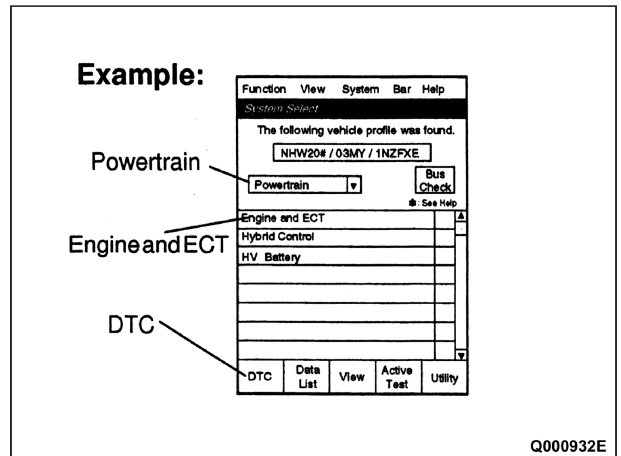

B. Check DTC (not using the DST-2)

- Turn the ignition switch ON.
- Using SST (09843-18040), connect between terminals 13 (TC) and 4 (CG) of the DLC3.

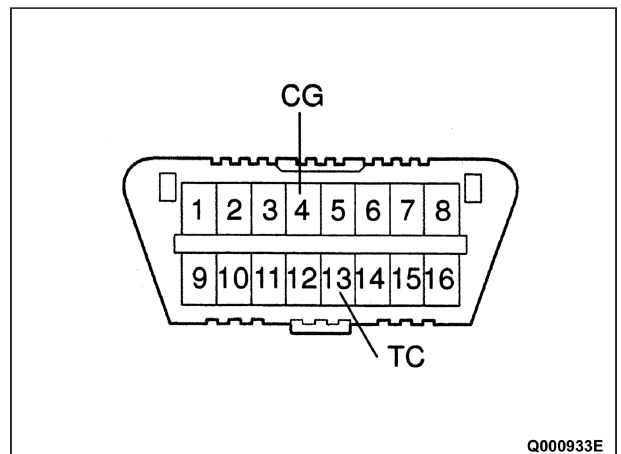

- c. Read DTCs by observing the MIL. If any DTC is not detected, the MIL blinks as shown in the illustration.

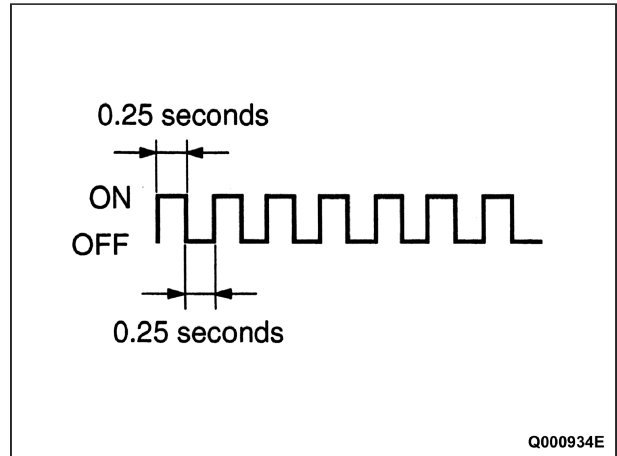

- d. Example: If DTCs 12 and 31 are detected, the MIL flashes once (for 0.5 second) and flashes twice after the 1.5 second interval, then, flashes 3 times after a 2.5 second interval from the previous DTC and flashes once. If the interval between the previous DTC and the next DTC is 4.5 seconds, it means the previous DTC is the last one of the multiple string DTCs. The MIL repeats the indication of DTCs from the initial cycle (refer to the illustration on the left).

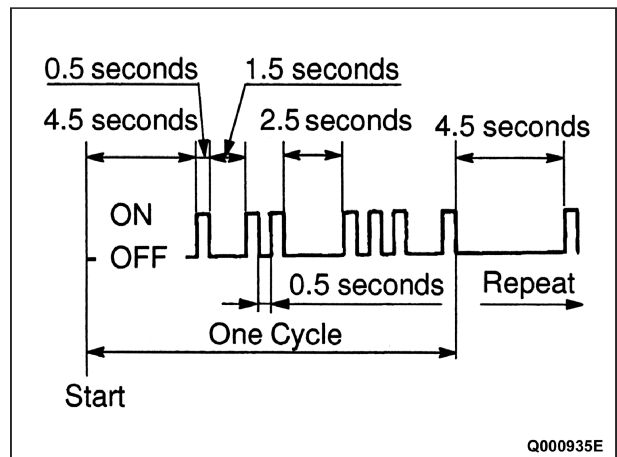

- e. Check the details of the malfunction using the DTC chart on page 48.
- f. After completing the check, disconnect terminals 13 (TC) and 4 (CG) and turn off the display.

< NOTE >

- If 2 or more DTCs are detected, the MIL will indicate the smaller number DTC first.

- g. See page 48 to confirm the details of the DTCs.
- C. Clear DTCs and Freeze Frame Data (using the DST-2)

- a. Connect the DST-2 to the DLC3.
- b. Turn the ignition switch ON (do not start the engine) and turn the DST-2 ON.
- c. Enter the following menus: Powertrain/Engine and ECT/ DTC/Clear.
- d. Erase DTCs and freeze frame data by pressing the YES button on the tester.

Example:

Function	View	System	Bar	Help
Hybrid Control / DTC				
Current DTC	1			
1	P0138	Collision sensor High Input		
Current	Pending	History	Clear	
DTC	Data List	View	Active Test	Utility

Clear

Q000936E

D. Clear DTCs and Freeze Frame Data (without using the DST-2)

a. Perform either one of the following operations.

- (1) Disconnect the battery negative (-) cable for more than 1 minute.
- (2) Remove the EFI fuse from the engine room R/B located inside the engine compartment for more than 1 minute.

< CAUTION >

- When disconnecting the battery cable, perform the INITIALIZE procedure.

4-3. CHECK MODE PROCEDURE

< NOTE >

- DST-2 only: Compared to normal mode, check mode is more sensitive to malfunctions. Therefore, check mode can detect the malfunctions that cannot be detected by normal mode. In check mode, the ECU sets DTCs using 1 trip detection logic.

< CAUTION >

- All the stored DTCs and freeze frame data are erased if: 1) the ECU is changed from normal mode to check mode or vice versa; 2) the ignition switch is turned from ON to ACC or OFF while in check mode. Before changing modes, always check and make a note of any DTCs and freeze frame data.

A. Check Mode Procedure

a. Make sure that the vehicle is in the following condition:

- (1) Battery voltage 11 V or more.
- (2) Throttle valve fully closed.
- (3) Shift lever in N position.
- (4) A/C switch turned OFF.

b. Turn the ignition switch OFF.

c. Connect the DST-2 to the DLC3.

d. Turn the ignition switch ON and turn the DST-2 ON.

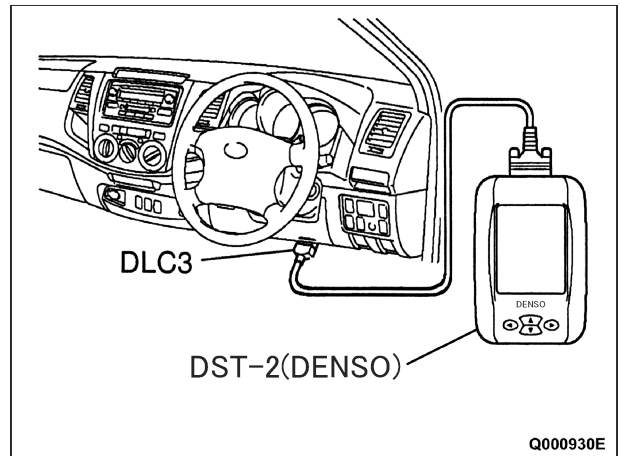

e. Enter the following menus: Powertrain/Engine and ECT/ Check Mode.

f. Make sure the MIL flashes as shown in the illustration.

g. Start the engine (the MIL should turn off).

h. Simulate the conditions of the malfunction described by the customer.

i. Check the DTC(s) and freeze frame data using the DST-2.

j. After checking the DTC, inspect the appropriate circuits.

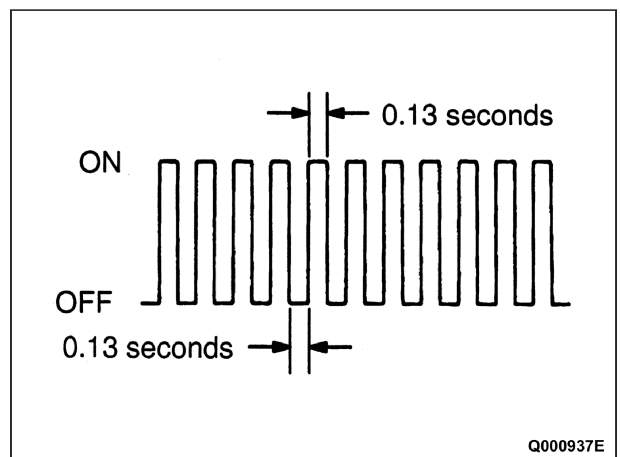

4-4. DTC (DIAGNOSTIC TROUBLE CODE) CHART

< NOTE >

- The parameters listed in the chart are for reference only. Factors such as instrument type may cause readings to differ slightly from stated values.
- If any DTCs are displayed during a check mode DTC check, check the circuit for the DTCs listed in the table below.

DTC No.	Detection Item	Trouble Area	*1 MIL	*2 Memory
P0045*3	Turbo/Super Charger Boost Control Solenoid Circuit/Open [Turbocharger system malfunction]	- Turbo motor driver - Open or short in turbo motor driver circuit - ECU	O	O
P0087/49	Fuel Rail/System Pressure - Too Low [Fuel pressure sensor system malfunction]	- Open or short in fuel pressure sensor circuit - Fuel pressure sensor - ECU	O	O
P0088/78	Fuel Rail/System Pressure - Too High [Common rail system malfunction]	- Supply pump (suction control valve) - Pressure limiter - Short in supply pump (suction control valve) circuit - ECU	O	O
P0093/78	Fuel System Leak Detected - Large Leak [Fuel leaks in common rail system]	- Fuel line between supply pump and common rail - Fuel line between common rail and each injector - Supply pump - Common rail - Injectors - Pressure limiter - Open or short in EDU circuit (P0200 set simultaneously) - Open or short in injector circuit - EDU (P0200 set simultaneously) - ECU	O	O
P0095/23*3,*4	Intake Air Temperature Sensor 2 Circuit [Intake air temperature sensor (intake air connector)]	- Open or short in diesel turbo IAT sensor circuit - Diesel turbo IAT sensor - ECU	O	O
P0097/23*3,*4	Intake Air Temperature Sensor 2 Circuit Low [Intake air temperature sensor low input (intake air connector)]		O	O
P0098/23*3,*4	Intake Air Temperature Sensor 2 Circuit High [Intake air temperature sensor high input (intake air connector)]		O	O

DTC No.	Detection Item	Trouble Area	*1 MIL	*2 Memory
P0100/31* ³	Mass or Volume Air Flow Circuit [Mass air flow meter]	- Open or short in MAF meter circuit - MAF meter - ECU	O	O
P0102/31* ³	Mass or Volume Air Flow Meter Circuit Low Input [Mass air flow meter low input]	- Open or short in MAF meter circuit - MAF meter - ECU	O	O
P0103/31* ³	Mass or Volume Air Flow Meter Circuit High Input [Mass air flow meter high input]		O	O
P0105/31	Manifold Absolute Pressure/ Barometric Pressure Circuit [Intake air pressure sensor]	- Open or short in manifold absolute pressure sensor circuit - Manifold absolute pressure sensor - Turbocharger sub-assy - EGR valve assy - ECU	O	O
P0107/31	Manifold Absolute Pressure/ Barometric Pressure Circuit Low Input [Intake air pressure sensor low input]	- Open or short in manifold absolute pressure sensor circuit - Manifold absolute pressure sensor - Turbocharger sub-assy - EGR valve assy	O	O
P0108/31	Manifold Absolute Pressure/ Barometric Pressure Circuit High Input [Intake air pressure sensor high input]	- ECU	O	O
P0110/24	Intake Air Temperature Circuit [Intake air temperature sensor (built into mass air flow meter)]	- Open or short in IAT sensor circuit - IAT sensor (built into MAF meter)* ¹ - IAT sensor* ^{4,5} - ECU	O	O
P0112/24	Intake Air Temperature Circuit Low Input [Intake air temperature sensor (built into mass air flow meter) low input]		O	O
P0113/24	Intake Air Temperature Circuit High Input [Intake air temperature sensor (built into mass air flow meter) high input]		O	O
P0115/22	Engine Coolant Temperature Circuit [Engine coolant temperature sensor]	- Open or short in ECT sensor circuit - ECT sensor - ECU	O	O

DTC No.	Detection Item	Trouble Area	*1 MIL	*2 Memory
P0117/22	Engine Coolant Temperature Circuit Low Input [Engine coolant temperature sensor low input]	- Open or short in ECT sensor circuit - ECT sensor - ECU	O	O
P0118/22	Engine Coolant Temperature Circuit High Input [Engine coolant temperature sensor high input]		O	O
P0120/41	Throttle/Pedal Position Sensor/Switch "A" Circuit[Intake shutter (throttle valve) position sensor]	- Open or short in throttle position sensor circuit - Throttle position sensor - ECU	O	O
P0122/41	Throttle/Pedal Position Sensor/Switch "A" Circuit Low Input[Intake shutter (throttle valve) position sensor low input]	- Throttle position sensor - Open or short in VLU circuit - Open in VC circuit - ECU	O	O
P0123/41	Throttle/Pedal Position Sensor/Switch "A" Circuit High Input[Intake shutter (throttle valve) position sensor high input]	- Throttle position sensor - Open in E2 circuit - VC and VTA circuits are short-circuited - ECU	O	O
P0168/39	Fuel Temperature Too High [Fuel temperature sensor rationality]	- Fuel temperature sensor	O	O
P0180/39	Fuel Temperature Sensor "A" Circuit [Fuel temperature sensor]	- Open or short in fuel temperature sensor circuit - Fuel temperature sensor - ECU	O	O
P0182/39	Fuel Temperature Sensor "A" Circuit Low Input [Fuel temperature sensor low input]		O	O
P0183/39	Fuel Temperature Sensor "A" Circuit High Input [Fuel temperature sensor high input]		O	O
P0190/49	Fuel Rail Pressure Sensor Circuit[Fuel pressure sensor]	- Open or short in fuel pressure sensor circuit - Fuel pressure sensor - ECU	O	O
P0192/49	Fuel Rail Pressure Sensor Circuit Low Input [Fuel pressure sensor low input]	- Open or short in fuel pressure sensor circuit - Fuel pressure sensor - ECU	O	O
P0193/49	Fuel Rail Pressure Sensor Circuit High Input [Fuel pressure sensor high input]		O	O

DTC No.	Detection Item	Trouble Area	*1 MIL	*2 Memory
P0200/97	Injector Circuit/Open[EDU system for injector malfunction]	- Open or short in EDU circuit - Injector - EDU - ECU	O	O
P0234*3	Turbo/Super Charger Overboost Condition [Turbocharger system malfunction]	- Turbocharger sub-assy - Turbo motor driver - Manifold absolute pressure sensor - ECU	O	O
P0299*3	Turbo/Super Charger Underboost Condition [Turbocharger system malfunction]		O	O
P0335/12	Crankshaft Position Sensor "A" Circuit [Crankshaft position sensor]	- Open or short in crankshaft position sensor circuit - Crankshaft position sensor - Sensor plate (crankshaft timing pulley)	O	O
P0339/13	Crankshaft Position Sensor "A" Circuit Intermittent [Crankshaft position sensor intermittent problem]	- ECU	/	O
P0340/12	Camshaft Position Sensor "A" Circuit (Bank 1 or Single Sensor) [Camshaft position sensor]	- Open or short in camshaft position sensor circuit - Camshaft position sensor - Camshaft timing pulley - ECU	O	O
P0400*4,*5	Exhaust Gas Recirculation Flow [EGR system malfunction]	- EGR valve stuck - EGR valve does not move smoothly - Open or short in E-VRV for EGR circuit - Open or short in EGR valve position sensor circuit - EGR valve position sensor - ECU	O	O
P0405*4,*5	Exhaust Gas Recirculation Sensor "A" Circuit Low [EGR lift sensor malfunction]	- Open or short in EGR valve position sensor circuit - EGR valve position sensor	O	O
P0406*4,*5	Exhaust Gas Recirculation Sensor "A" Circuit High [EGR lift sensor malfunction]	- ECU	O	O
P0488/15	Exhaust Gas Recirculation Throttle Position Control Range/Performance [Intake shutter]	- Open or short in diesel throttle control motor circuit - Open or short in diesel throttle valve fully opened switch circuit - Diesel throttle valve assy - ECU	O	O

DTC No.	Detection Item	Trouble Area	*1 MIL	*2 Memory
P0500/42	Vehicle Speed Sensor "A" [Vehicle speed sensor]	- Open or short in speed sensor circuit - Speed sensor - Combination meter - ECU - Skid control ECU	O	O
P0504/51	Brake Switch "A"/"B" Correlation [Stop lamp rationality]	- Short in stop lamp switch signal circuit - Stop lamp switch - ECU	/	O
P0606	ECU/PCM Processor [ECU]	- ECU	/	/
P0607	Control Module Performance [ECU]		O	O
P0627	Fuel Pump Control Circuit/Open [Common rail system malfunction]	- Open or shot in suction control valve circuit - Suction control valve - ECU	O	O
P1229/78	Fuel Pump System[Common rail system malfunction]	- Short in supply pump (suction control valve) circuit - Supply pump (suction control valve) - ECU	O	O
P1251*3	Step Motor For Turbocharger Control Circuit (Intermittent) [Turbocharger system malfunction]	- Turbo motor driver - Open or short in turbo motor driver circuit - Turbocharger sub-assy - ECU	O	O
P1601/89	Injector Correction Circuit (EEPROM) [ECU]	- Injector compensation code - ECU	O	O
P1611/17	IC Circuit Malfunction [ECU]	- ECU	O	O
P2008*3	Intake Manifold Runner Control Circuit/Open (Bank 1) [Swirl control system malfunction]	- VSV for swirl control valve - Open or short in VSV for swirl control valve - Intake manifold (swirl control valve) - ECU	O	O
P2120/19	Throttle/Pedal Position Sensor/Switch "D" Circuit [Accelerator pedal position sensor (sensor 1)]	- Open or short in accelerator pedal position sensor circuit - Accelerator pedal position sensor - ECU	O	O
P2121/19	Throttle/Pedal Position Sensor/Switch "D" Circuit Range/Performance [Accelerator pedal position sensor rationality (sensor 1)]	- Accelerator pedal position sensor circuit - Accelerator pedal position sensor - ECU	O	O

DTC No.	Detection Item	Trouble Area	*1	*2
			MIL	Memory
P2122/19	Throttle/Pedal Position Sensor/ Switch "D" Circuit Low Input [Accelerator pedal position sensor low input (sensor 1)]	- Open or short in accelerator pedal position sensor circuit - Accelerator pedal position sensor - ECU	O	O
P2123/19	Throttle/Pedal Position Sensor/ Switch "D" Circuit High Input [Accelerator pedal position sensor high input (sensor 1)]		O	O
P2125/19	Throttle/Pedal Position Sensor/ Switch "E" Circuit [Accelerator pedal position sensor (sensor 2)]		O	O
P2127/19	Throttle/Pedal Position Sensor/ Switch "E" Circuit Low Input [Accelerator pedal position sensor low input (sensor 2)]		O	O
P2128/19	Throttle/Pedal Position Sensor/ Switch "E" Circuit High Input [Accelerator pedal position sensor high input (sensor 2)]		O	O
P2138/19	Throttle/Pedal Position Sensor/ Switch "D"/"E" Voltage Correlation [Accelerator pedal position sensor malfunction]		O	O
P2226/A5*6	Barometric Pressure Circuit [ECU]		- ECU	O
P2228/A5*6	Barometric Pressure Circuit Low Input [ECU]	O		O
P2229/A5*6	Barometric Pressure Circuit High Input [ECU]	O		O
U0001/A2*6	High Speed CAN Communication Bus	- Open or short TCM and ECU circuit- TCM- ECU	/	O
B2799	Engine Immobilizer System Malfunction	- Immobilizer system	/	O

< NOTE >

- *1: "O": MIL (Malfunction Indicator Lamp) illuminates, "/": MIL does not illuminate.
- *2: "O": DTC is stored in the ECU, "/": DTC is not stored in the ECU.
- *3: Only for 1KD-FTV.
- *4: Only for 2KD-FTV (w/ CAC).
- *5: Only for 2KD-FTV (w/o CAC).
- *6: "A" in the above table indicates that the MIL flashes 10 times.

4-5. FAIL-SAFE CHART

A. Fail-Safe Chart

If any of the following DTCs are set, the ECU enters fail-safe mode to allow the vehicle to be driven temporarily.

DTC No.	Detection Item	Fail-Safe Operation	Fail-Safe Deactivation Conditions
P0045	Turbo/Super Charger Boost Control Solenoid Circuit/Open [Turbocharger system malfunction]	Limits engine power	Ignition switch OFF
P0087/49	Fuel Rail/System Pressure - Too Low [Fuel pressure sensor system malfunction]	Limits engine power	Ignition switch OFF
P0088/78	Fuel Rail/System Pressure - Too High [Common rail system malfunction]	Limits engine power	Ignition switch OFF
P0093/78	Fuel System Leak Detected - Large Leak [Fuel leaks in common rail system]	Limits engine power for 1 minute and then stalls the engine	Ignition switch OFF
P0095/23 ^{*1,2}	Intake Air Temperature Sensor 2 Circuit [Intake air temperature sensor (intake air connector)]	Intake air (intake manifold) temperature fixed at 145°C (293°F)	Pass condition detected
P0097/23 ^{*1,2}	Intake Air Temperature Sensor 2 Circuit Low [Intake air temperature sensor low input (intake air connector)]		
P0098/23 ^{*1,2}	Intake Air Temperature Sensor 2 Circuit High [Intake air temperature sensor high input (intake air connector)]		
P0100/31 ^{*1}	Mass or Volume Air Flow Circuit [Mass air flow meter]	Limits engine power	Pass condition detected
P0102/31 ^{*1}	Mass or Volume Air Flow Meter Circuit Low Input [Mass air flow meter low input]		
P0103/31 ^{*1}	Mass or Volume Air Flow Meter Circuit High Input [Mass air flow meter high input]		

DTC No.	Detection Item	Fail-Safe Operation	Fail-Safe Deactivation Conditions
P0105/31	Manifold Absolute Pressure/Barometric Pressure Circuit [Intake air pressure sensor]	Turbo pressure fixed at specified value	Pass condition detected
P0107/31	Manifold Absolute Pressure/Barometric Pressure Circuit Low Input [Intake air pressure sensor low input]		
P0108/31	Manifold Absolute Pressure/Barometric Pressure Circuit High Input [Intake air pressure sensor high input]		
P0110/24	Intake Air Temperature Circuit [Intake air temperature sensor (built into mass air flow meter)]	Intake air (mass air flow meter) temperature value fixed	Pass condition detected
P0112/24	Intake Air Temperature Circuit Low Input [Intake air temperature sensor (built into mass air flow meter) low input]		
P0113/24	Intake Air Temperature Circuit High Input [Intake air temperature sensor (built into mass air flow meter) high input]		
P0115/22	Engine Coolant Temperature Circuit [Engine coolant temperature sensor]	Fuel temperature sensor output fixed at specified value (fixed value varies depending on conditions)	Pass condition detected
P0117/22	Engine Coolant Temperature Circuit Low Input [Engine coolant temperature sensor low input]		
P0118/22	Engine Coolant Temperature Circuit High Input [Engine coolant temperature sensor high input]		
P0120/41	Throttle/Pedal Position Sensor/Switch "A" Circuit	Limits engine power	Ignition switch OFF
P0122/41	Throttle/Pedal Position Sensor/Switch "A" Circuit Low Input		
P0123/41	Throttle/Pedal Position Sensor/Switch "A" Circuit High Input		
P0168/39	Fuel Temperature Too High [Fuel temperature sensor rationality]	Limits engine power	Pass condition detected

DTC No.	Detection Item	Fail-Safe Operation	Fail-Safe Deactivation Conditions
P0180/39	Fuel Temperature Sensor "A" Circuit [Fuel temperature sensor]	Fuel temperature fixed at 40°C (104°F)	Pass condition detected
P0182/39	Fuel Temperature Sensor "A" Circuit Low Input [Fuel temperature sensor low input]		
P0183/39	Fuel Temperature Sensor "A" Circuit High Input [Fuel temperature sensor high input]		
P0190/49	Fuel Rail Pressure Sensor Circuit [Fuel pressure sensor]	Limits engine power	Ignition switch OFF
P0192/49	Fuel Rail Pressure Sensor Circuit Low Input [Fuel pressure sensor low input]		
P0193/49	Fuel Rail Pressure Sensor Circuit High Input [Fuel pressure sensor high input]		
P0200/97	Injector Circuit/Open [EDU system for injector malfunction]	Limits engine power	Ignition switch OFF
P0234*1	Turbo/Super Charger Excessive Boost [Turbocharger system malfunction]	Limits engine power	Ignition switch OFF
P0299*1	Turbo/Super Charger Insufficient Boost [Turbocharger system malfunction]	Limits engine power	Ignition switch OFF
P0335/12	Crankshaft Position Sensor "A" Circuit [Crankshaft position sensor]	Limits engine power	Pass condition detected
P0340/12	Camshaft Position Sensor "A" Circuit (Bank 1 or Single Sensor) [Camshaft position sensor]	Limits engine power	Pass condition detected
P0488/15	Exhaust Gas Recirculation Throttle Position Control Range/Performance [Intake shutter]	Limits engine power	Ignition switch OFF
P0500/42	Vehicle Speed Sensor "A" [Vehicle speed sensor]	Vehicle speed fixed at 0 km/h (0 mph)	Pass condition detected
P0627/78	Fuel Pump Control Circuit/Open [Common rail system malfunction]	Limits engine power	Pass condition detected
P1229/78	Fuel Pump System[Common rail sys- tem malfunction]	Limits engine power	Ignition switch OFF
P1251*1	Turbo/Super Charger Excessive Boost (Too High) [Turbocharger system malfunction]	Limits engine power	Ignition switch OFF
P1611/17	IC Circuit Malfunction[ECU]	Limits engine power	Ignition switch OFF

DTC No.	Detection Item	Fail-Safe Operation	Fail-Safe Deactivation Conditions
P2120/19	Throttle/Pedal Position Sensor/Switch "D" Circuit [Accelerator pedal position sensor (sensor 1)]	Limits engine power	Ignition switch OFF
P2121/19	Throttle/Pedal Position Sensor/Switch "D" Circuit Range/Performance [Accelerator pedal position sensor rationality (sensor 1)]		
P2122/19	Throttle/Pedal Position Sensor/Switch "D" Circuit Low Input [Accelerator pedal position sensor low input (sensor 1)]		
P2123/19	Throttle/Pedal Position Sensor/Switch "D" Circuit High Input [Accelerator pedal position sensor high input (sensor 1)]		
P2125/19	Throttle/Pedal Position Sensor/Switch "E" Circuit [Accelerator pedal position sensor (sensor 2)]		
P2127/19	Throttle/Pedal Position Sensor/Switch "E" Circuit Low Input [Accelerator pedal position sensor low input (sensor 2)]		
P2128/19	Throttle/Pedal Position Sensor/Switch "E" Circuit High Input [Accelerator pedal position sensor high input (sensor 2)]		
P2138/19	Throttle/Pedal Position Sensor/Switch "D"/"E" Voltage Correlation [Accelerator pedal position sensor malfunction]		
P2226/A5	Barometric Pressure Circuit [ECU]	Atmospheric pressure fixed	Pass condition detected
P2228/A5	Barometric Pressure Circuit Low Input [ECU]		
P2229/A5	Barometric Pressure Circuit High Input [ECU]		

< NOTE >

- *1: Only for 1KD-FTV.
- *2: Only for 2KD-FTV (w/ CAC).
- *3: Only for 2KD-FTV (w/o CAC).

4-6. EXTERNAL WIRING DIAGRAM

A. External ECU Wiring Diagram

a. Wiring Diagram (1)

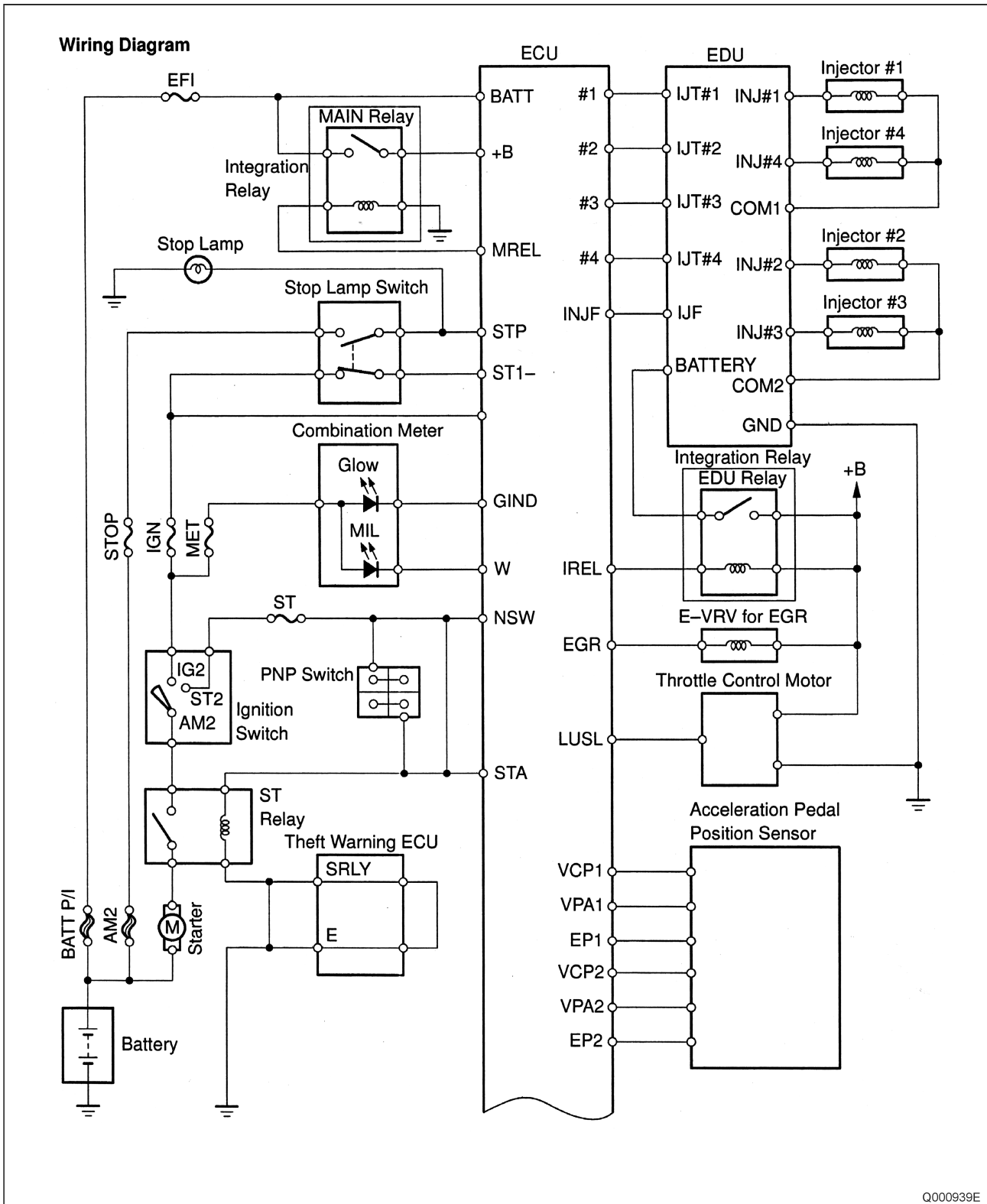

Q000939E

b. Wiring Diagram (2)

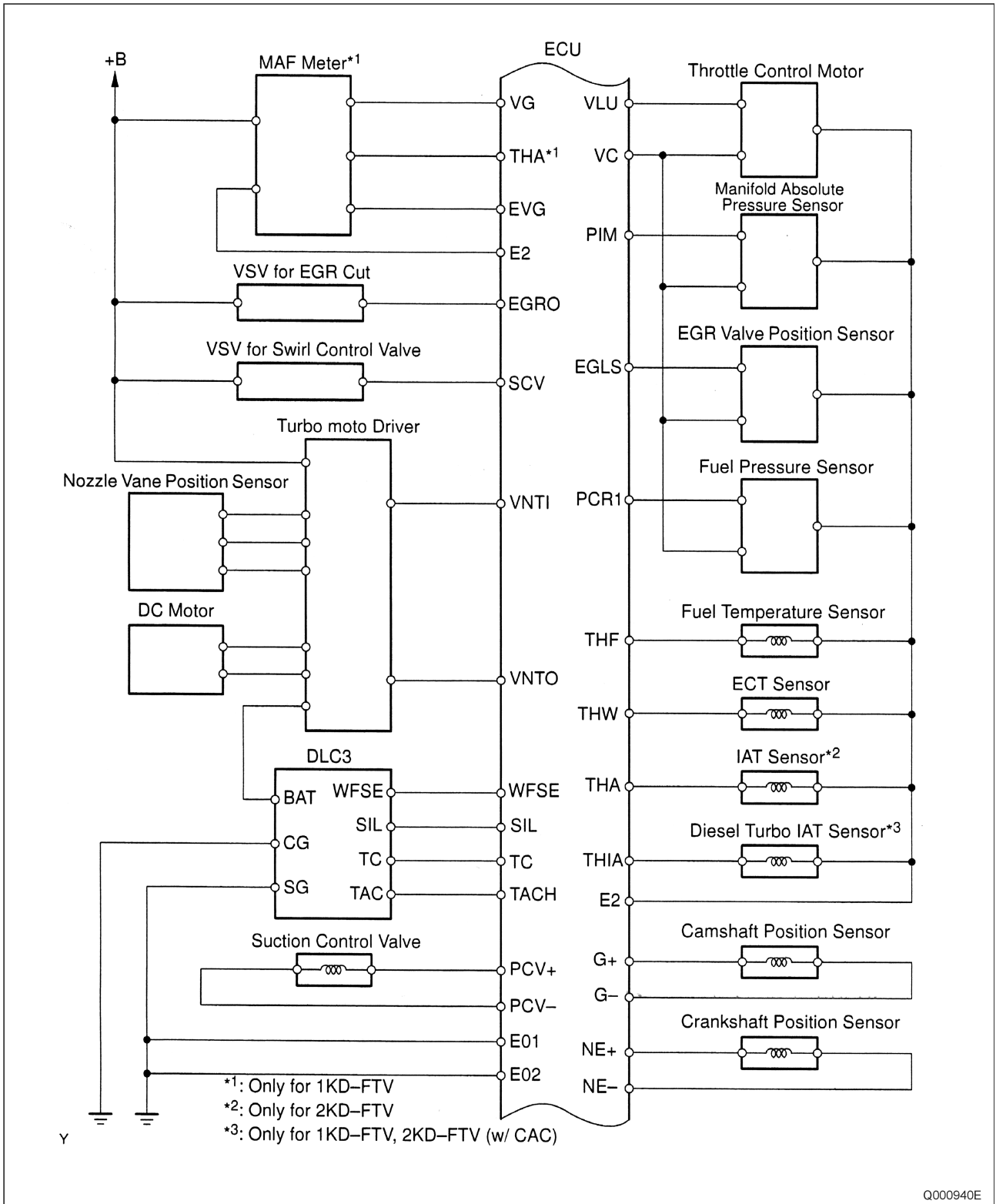

Q000940E

c. Wiring Diagram (3)

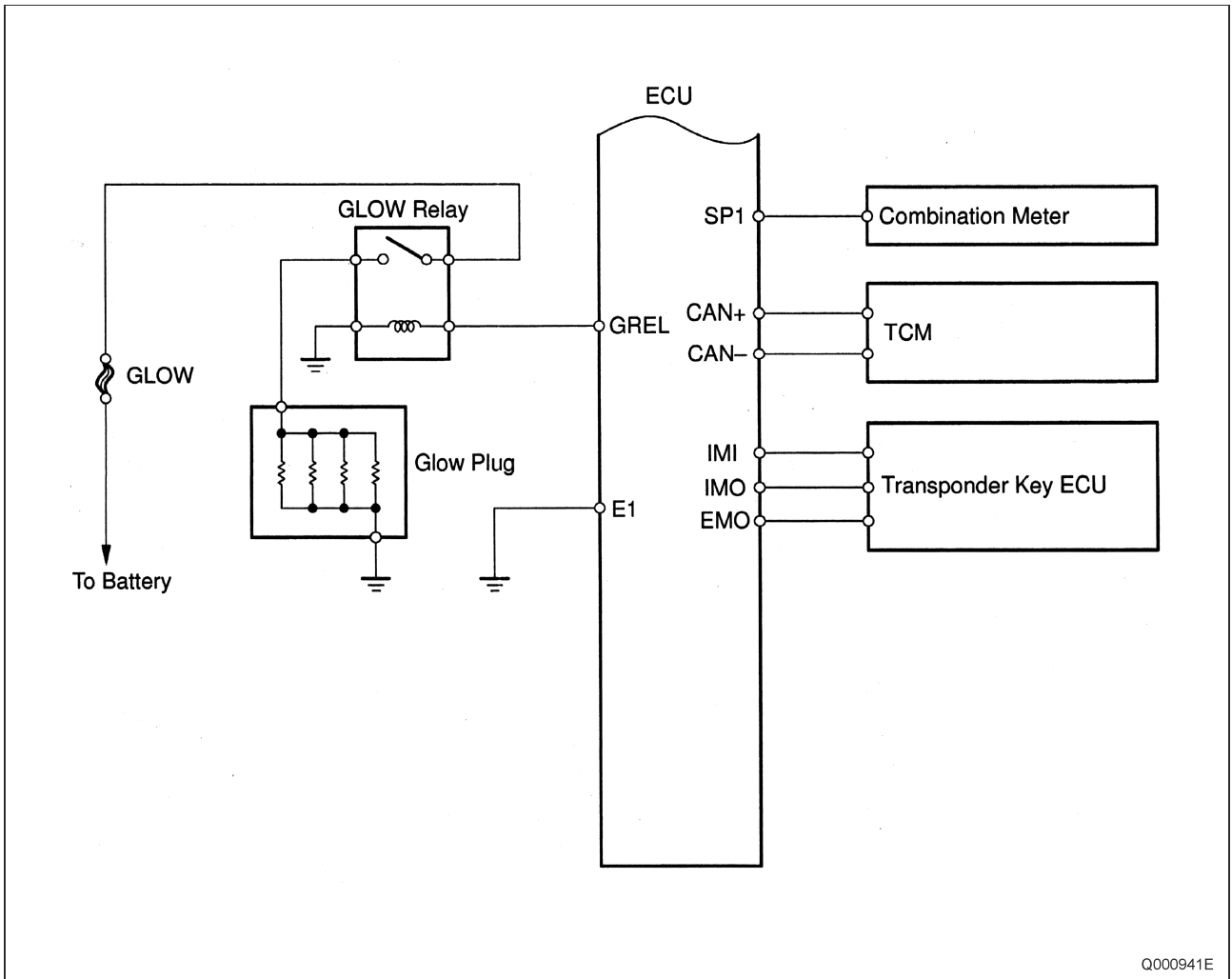

Q000941E

B. ECU Connector Diagram

a. Connector Terminal Layout

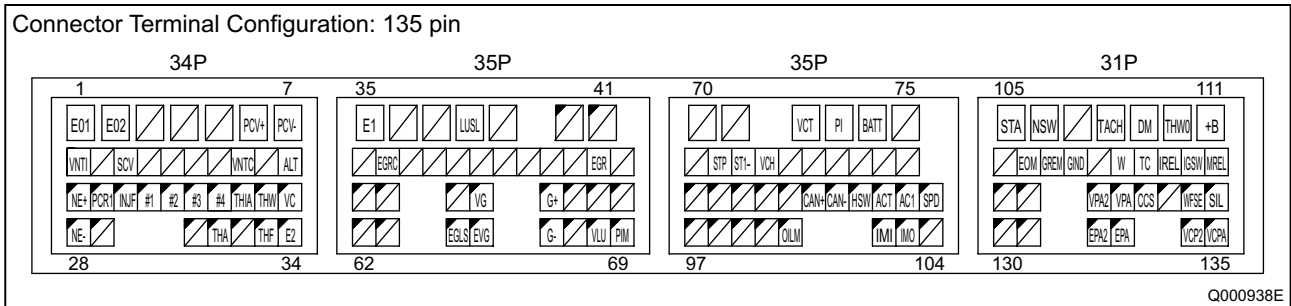

< NOTE >

- The standard normal voltage between each pair of ECU terminals is shown in the table below. The appropriate conditions for checking each pair of terminals are also indicated.
- The result of checks should be compared with the standard normal voltage for that pair of terminals, displayed in the Specified Condition column.
- The illustration above can be used as a reference to identify the ECU terminal locations.

Symbols (Terminal No.)	Wiring Color	Terminal Description	Condition	Specified Condition
BATT (E6-2) - E1 (E8-7)	L-BR	Battery (for measuring battery voltage and for ECU memory)	Always	9 to 14 V
IGSW (E5-9) - E1 (E8-7)	B-O-BR	Ignition switch	Ignition switch ON	9 to 14 V
+B (E5-1) - E1 (E8-7)	B-BR	Power source of ECU	Ignition switch ON	9 to 14 V
MREL (E5-8) - E1 (E8-7)	W-G-BR	MAIN Relay	Ignition switch ON	9 to 14 V
			Ignition switch OFF	0 to 1.5 V
VC (E7-18) - E1 (E8-7)	R-W-BR	Power source of sensor (a specific voltage)	Ignition switch ON	4.5 to 5.5 V
VPA1 (E5-22) - EP1 (E5-28)	W-L-BR-W	Accelerator pedal position sensor (for engine control)	Ignition switch ON, accelerator pedal fully released	0.5 to 11 V
			Ignition switch ON, accelerator pedal fully depressed	2.6 to 4.5 V
VPA2 (E5-23) - EP2 (E5-29)	GR-G-BR-Y	Accelerator pedal position sensor (for sensor malfunction detection)	Ignition switch ON, accelerator pedal fully released	1.2 to 2.0 V
			Ignition switch ON, accelerator pedal fully depressed	3.4 to 5.0 V
VCP1 (E5-26) - EP1 (E5-28)	LG-R-BR-W	Power source of accelerator pedal position sensor (for VPA)	Ignition switch ON	4.5 to 5.0 V
VCP2 (E5-27) - EP2 (E5-29)	BR-R-BR-Y	Power source of accelerator pedal position sensor (for VPA2)	Ignition switch ON	4.5 to 5.0 V
VG (E8-24) - EVG (E8-32)	W-R-B-W	MAF meter	Idling, A/C switch OFF	0.5 to 3.4 V
THA (E7-31) - E2 (E7-28)	Y-B-BR	IAT sensor	Idling, intake air temperature at 20°C (68°F)	0.5 to 3.4 V
	Y-G-BR			
THIA (E7-20) - E2 (E7-28)	Y-G-BR	Diesel turbo IAT sensor	Atmospheric air temperature	0.5 to 3.4 V

Symbols (Terminal No.)	Wiring Color	Terminal Description	Condition	Specified Condition
THW (E7-19) - E2 (E7-28)	R-L-BR	ECT sensor	Idling, engine coolant temperature at 80°C (176°F)	0.2 to 1.0 V
STA (E5-7) - E1 (E8-7)	B-Y-BR L-Y-BR	Starter signal	Cranking	6.0 V or more
#1 (E7-24) - E1 (E8-7) #2 (E7-23) - E1 (E8-7) #3 (E7-22) - E1 (E8-7) #4 (E7-21) - E1 (E8-7)	B-W-BR R-BR V-BR Y-R-BR	Injector	Idling	Pulse generation
G + (E8-23) - G - (E8-31)	Y-L	Camshaft position sensor	Idling	Pulse generation
NE + (E7-27) - NE - (E7-34)	Y-L	Crankshaft position sensor	Idling	Pulse generation
STP (E6-15) - E1 (E8-7)	G-W-BR	Stop lamp switch	Ignition switch ON, brake pedal depressed	7.5 to 14 V
			Ignition switch ON, brake pedal released	0 to 1.5 V
ST1 - (E6-14) - E1 (E8-7)	R-L-BR	Stop lamp switch (opposite to STP)	Ignition switch ON, brake pedal depressed	0 to 1.5 V
			Ignition switch ON, brake pedal released	7.5 to 14 V
TC (E5-11) - E1 (E8-7)	P-W-BR	Terminal TC of DLC3	Ignition switch ON	9 to 14 V
W (E5-12) - E1 (E8-7)	R-B-BR	MIL	MIL illuminated	0 to 3 V
			MIL not illuminated	9 to 14 V
SP1 (E6-17) - E1 (E6-7)	V-R-BR	Speed signal from combination meter	Ignition switch ON, rotate driving wheel slowly	Pulse generation
SIL (E5-18) - E1 (E6-7)	R-Y-BR	Terminal SIL of DLC3	Connect the DST-2 to the DLC3	Pulse generation
PIM (E8-28) - E2 (E7-28)	L-B-BR	Manifold absolute pressure sensor	Apply negative pressure of 40 kPa (300 mmHg, 11.8 in.Hg)	1.2 to 1.6 V
			Same as atmospheric pressure	1.3 to 1.9 V
			Apply positive pressure of 69 kPa (518 mmHg, 20.4 in.Hg)	3.2 to 3.8 V
IREL (E5-10) - E1 (E8-7)	B-W-BR	EDU relay	Ignition switch OFF	9 to 14 V
			Idling	0 to 1.5 V
TACH (E5-4) - E1 (E8-7)	B-W-BR	Engine speed	Idling	Pulse generation
PCR1 (E7-26) - E2 (E7-28)	R-Y-BR	Common rail pressure sensor (main)	Idling	1.3 to 1.8 V
GREL (E5-15) - E1 (E8-7)	R-BR	GLOW relay	Cranking	9 to 14 V
			Idling	0 to 1.5 V

Symbols (Terminal No.)	Wiring Color	Terminal Description	Condition	Specified Condition
THF (E7-29) - E2 (E7-28)	G-B-BR	Fuel temperature sensor	Ignition switch ON	0.5 to 3.4 V
ALT (E7-8) - E1 (E6-7)	G-BR	Generator duty ratio	Idling	Pulse generation
PCV + (E7-2) - PCV - (E7-1)	G-W-G-Y	Suction control valve	Idling	Pulse generation
INJF (E7-25) - E1 (E8-7)	P-BR	EDU	Idling	Pulse generation
VNTO (E7-10) - E1 (E8-7)	B-O-BR	Turbo motor driver	Ignition switch ON	Pulse generation
VNTI (E7-17) - E1 (E8-7)	R-B-BR	Turbo motor driver	Ignition switch ON	Pulse generation
VLU (E8-29) - E2 (E7-28)	B-BR	Throttle position sensor	Ignition switch ON, intake shutter (throttle valve) fully opened	3.0 to 4.0 V
			Ignition switch ON, intake shutter (throttle valve) fully closed	0.4 to 1.0 V
LUSL (E8-4) - E2 (E7-28)	GR-BR	Diesel throttle duty signal	Engine warmed up, racing engine	Pulse generation
EGLS (E8-33) - E2 (E7-28)	L-Y-BR	EGR valve position sensor	Ignition switch ON	0.6 to 1.4 V

C. EDU External Wiring Diagram

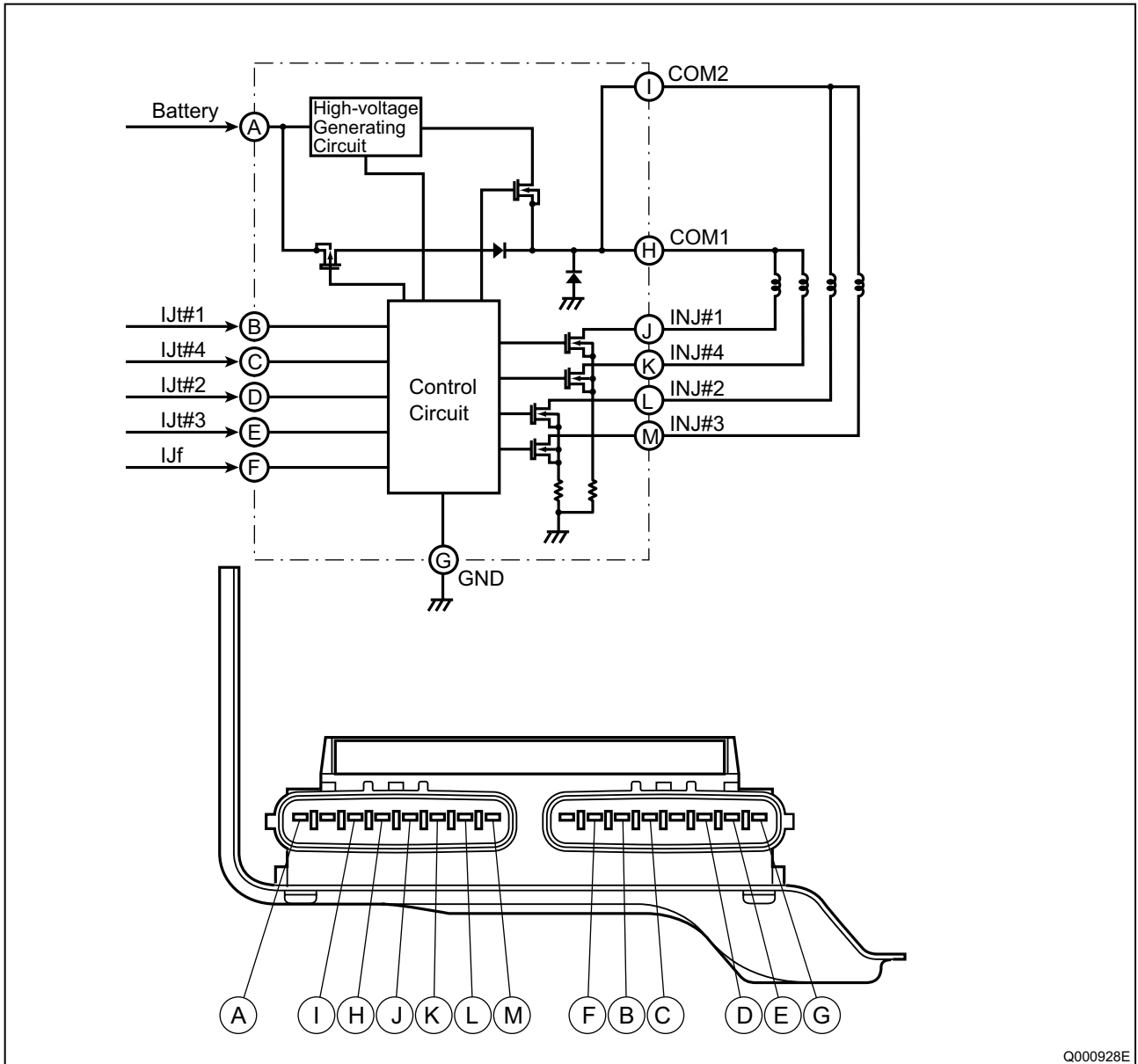

Q000928E

Published : July 2004

Edited and published by:

DENSO CORPORATION

Service Department

1-1 Showa-cho, Kariya, Aichi Prefecture, Japan